



Carriage House Door

COMPANY

RESIDENTIAL
OVERHEAD DOOR
INSTALLATION MANUAL



Figure 1

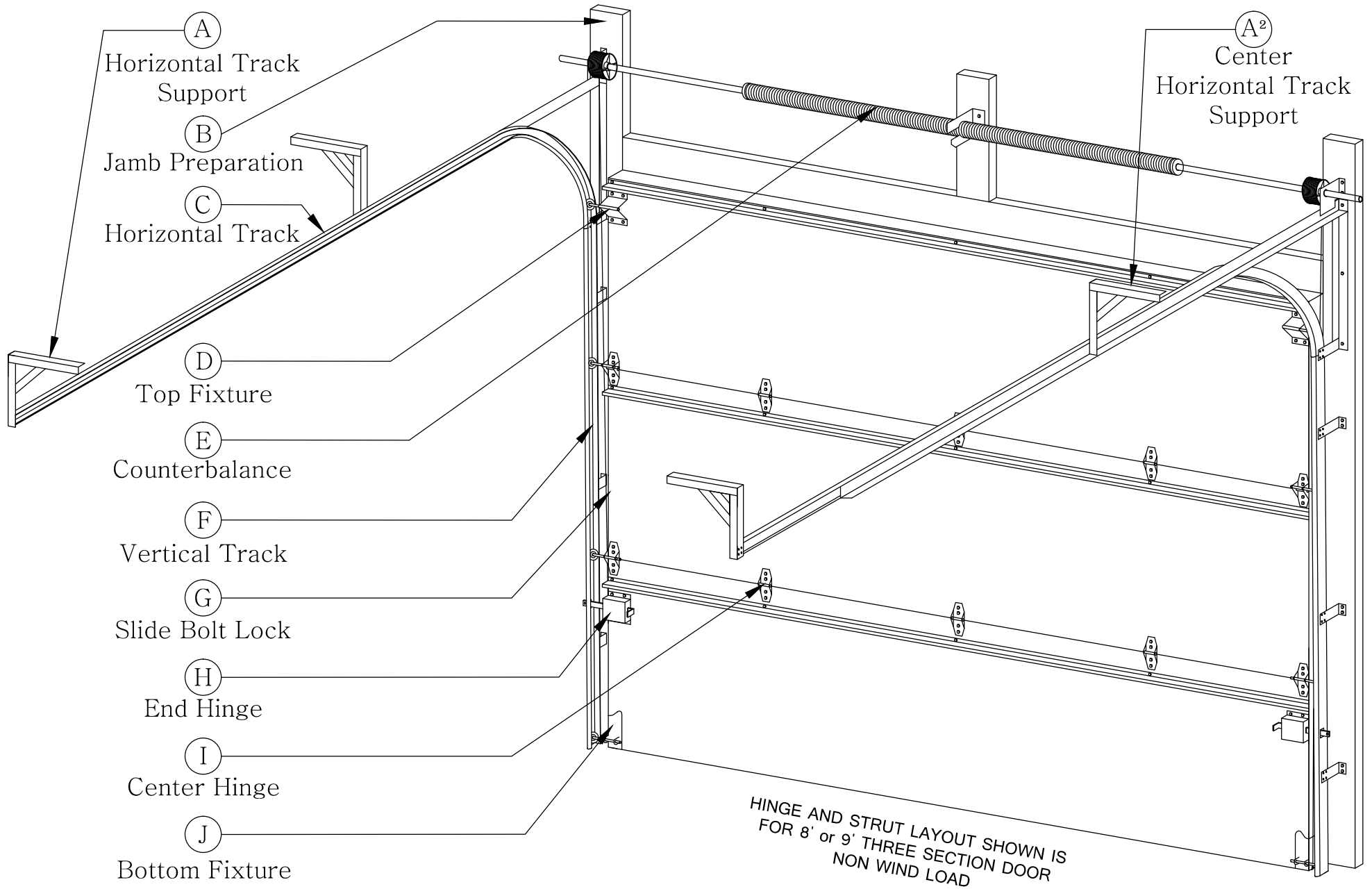
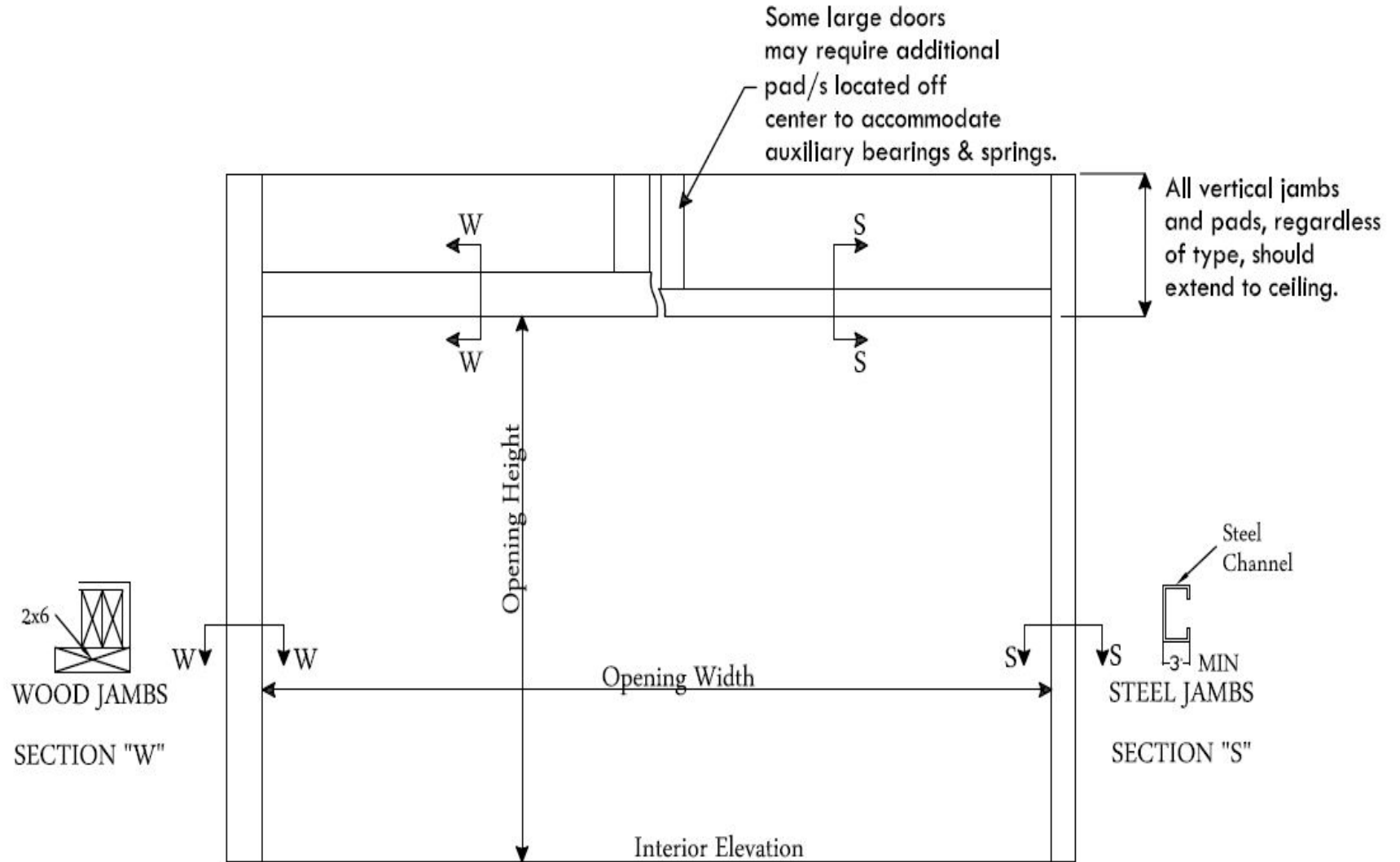

Figure 2



Pre Installation

- A. Start by checking width and height of opening, and compare it to width and height of door to make sure they are the same size +/-.
- B. Inspect track and determine if you have bracket mount, angle mount/reverse angle mount tracks. Note: bracket mount has individual track brackets to attach track to jamb. Angle mount/reverse angle has a continuous angle to attach track to jamb (shown Figure 3). If door was requested with reverse angle mount track. The door will need to be two inches wider than the opening.
- C. Check to make sure that the opening is ready for door installation. (Figure 2)

Figure 3

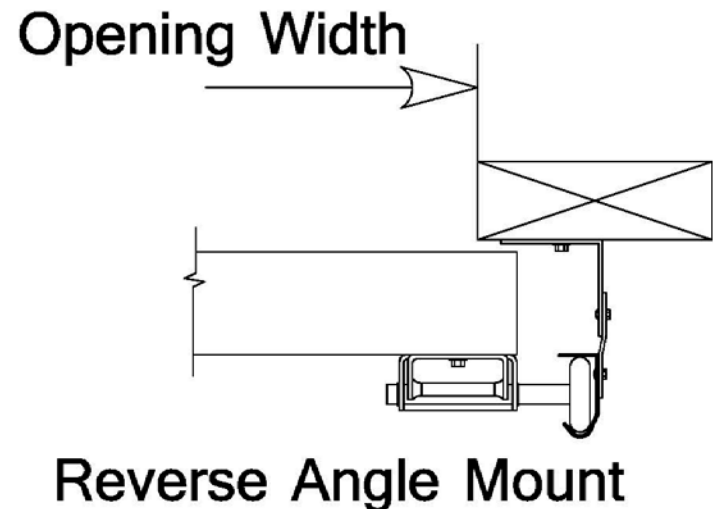
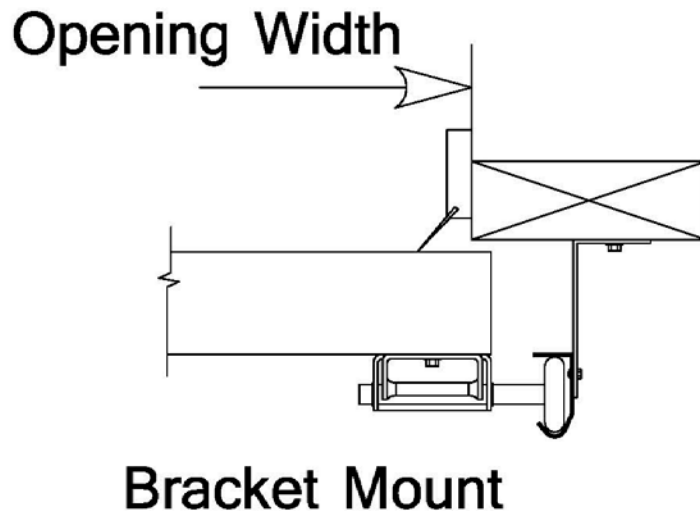

Door Installation

1. Start by removing the bottom rubber from the door, this does not include the black membrane underneath, only remove the ridged bottom rubber.
2. Start with number one section (bottom). Place $\frac{1}{2}$ " blocks under left and right side of section. center and level section in the opening.

Tip: Make holding brackets out of extra #14 jamb bracket. Bend into a "z" shape or you can use a nail into the jamb. (Do not use #14 jamb brackets if provided in hardware box)

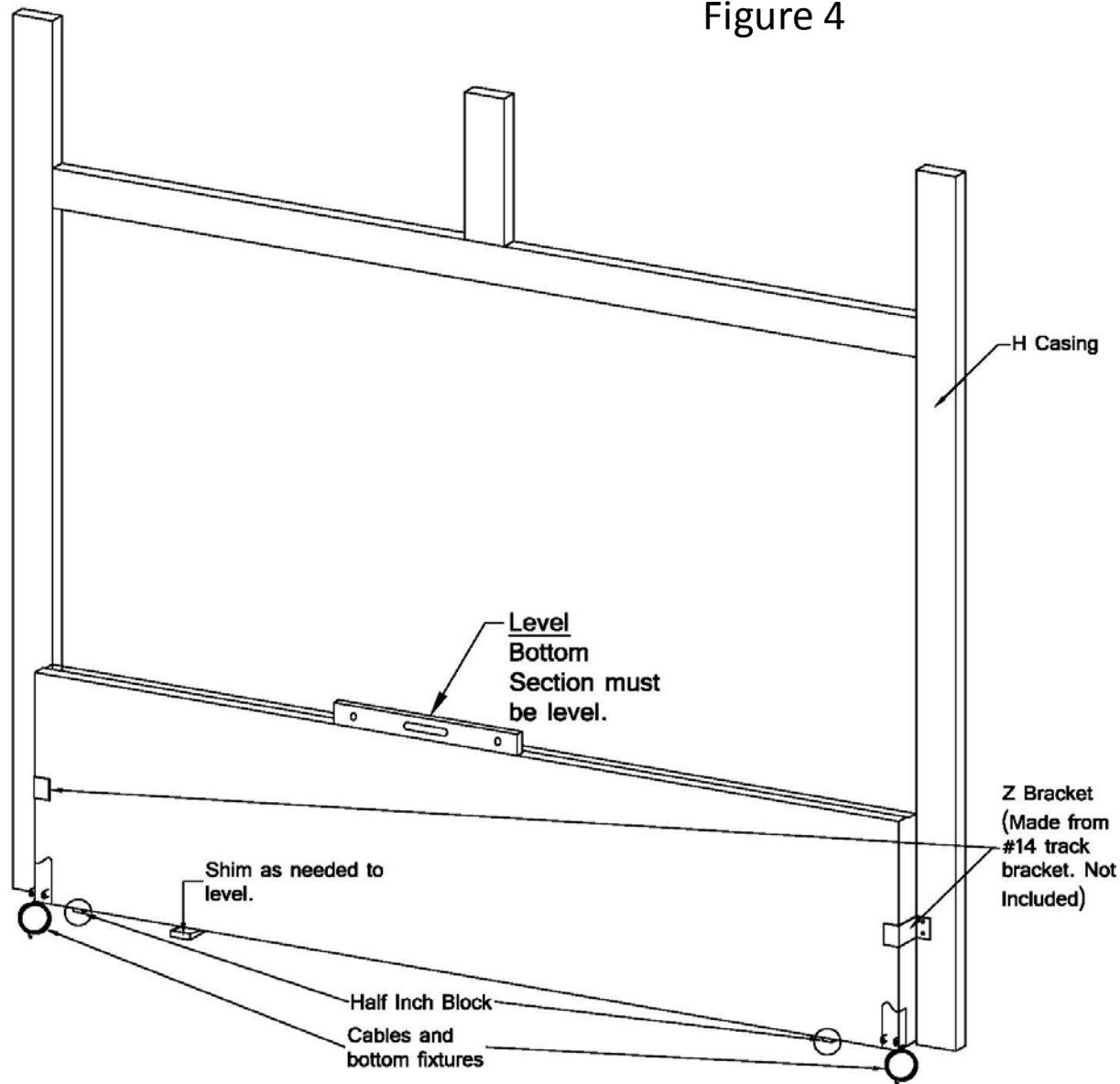

3. Place “z” bracket or nail into the jamb on **Both Sides** to hold #1 section upright against opening.
4. Remove bottom fixtures, pins ,cables and carter pins from hardware box. Slide pins through bottom fixtures through cable loops, and secure from outside with carter pin, repeat for both bottom fixtures and attach to bottom section. (Figure 5)
5. Stack #2 section on top of #1 section.
6. Attach a “z” bracket or use nail into jamb on either end.

Tip: Check front of sections to make sure that face and trim is aligned.

7. Attach first #1 hinge in correct layout for the sections starting with the bottom hole working up.
8. Outside hinges between first and second section should start #2 (stamped on hinge). Attach #2 hinges at the edges of the first and second section starting with the bottom hole and working up. (Figure #6)
9. Stack #3 section on top of #2 section, and secure against wall on opposite end of previous section with nail or “z” bracket.

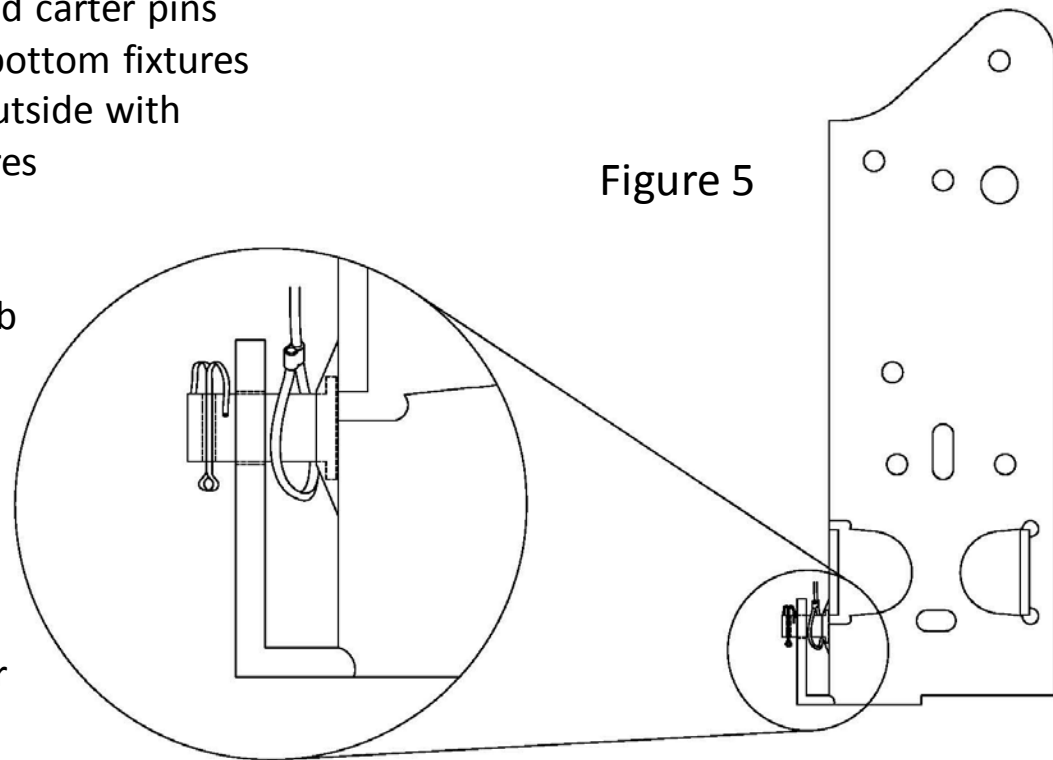

9. Check front of door to make sure face is aligned and repeat steps 8 and 9 making sure to increase the size of your outside hinge i.e. #3, #4, #5. (Figure 7)
10. Keep repeating these steps until the entire door is stacked in the opening. For the top section secure to the wall with nail or "z" bracket at the top of the section. (**NOT AT THE EDGE**) (SEE Figure 4)

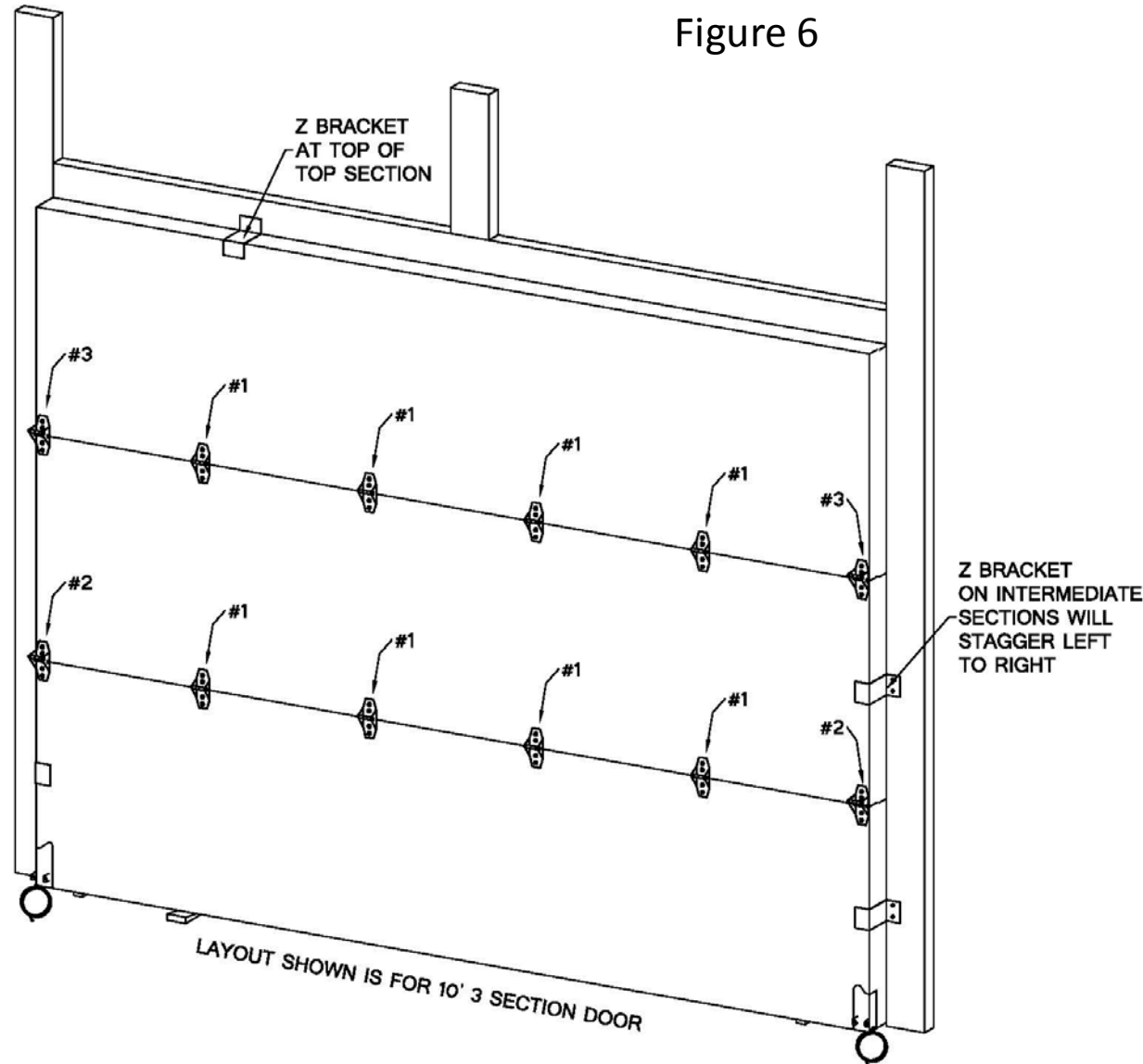

Tip: Check front of sections to make sure that face and trim is aligned.

11. Once all sections are stacked attach remaining intermediate #1 hinges. Some doors may be provided with half hinges, they will need to be predrilled prior to attaching to door (usually centered below windows)

Figure 7

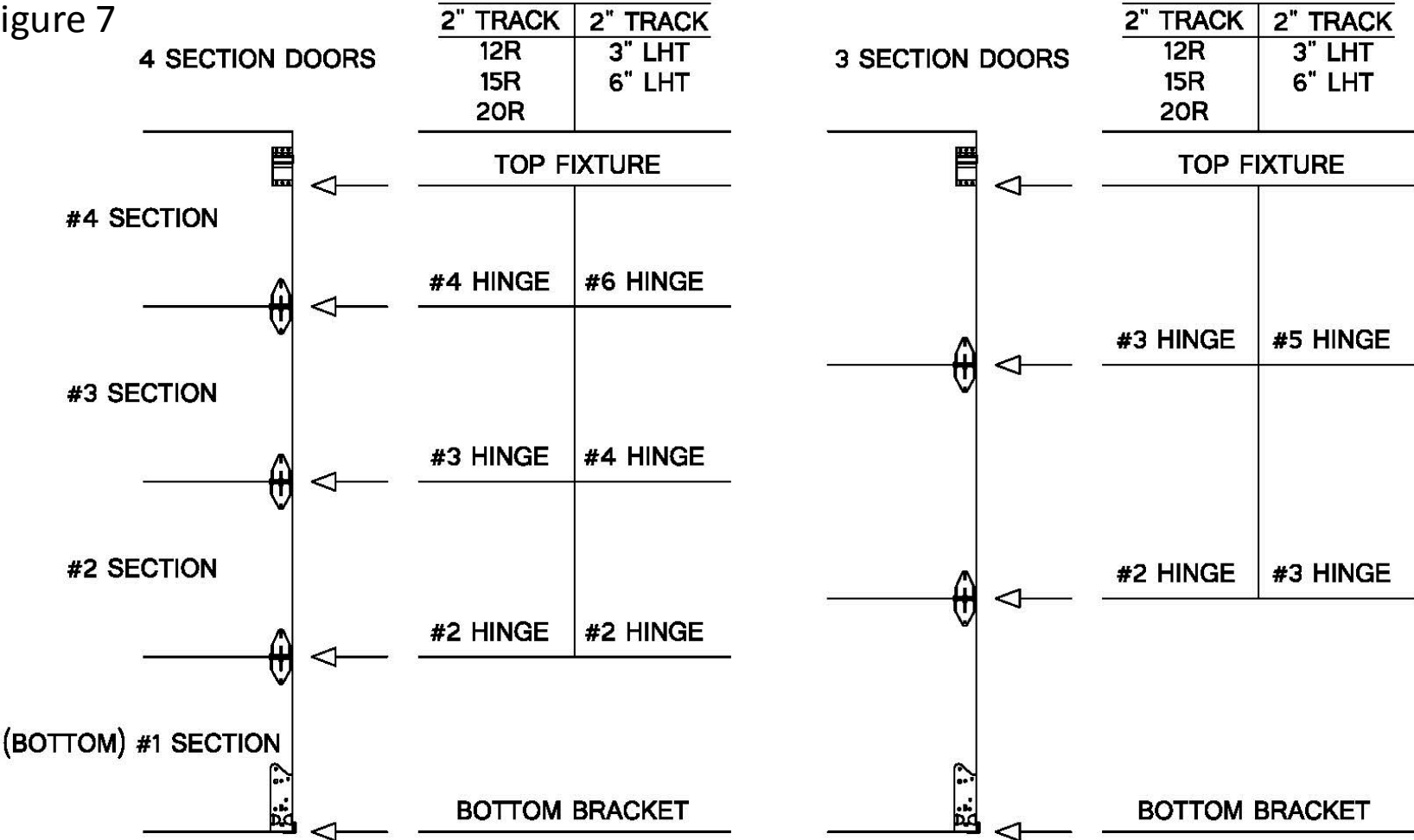

12. Remove verticals from inside bound track. Square punch location is closest to bottom of the vertical track. To differentiate left from right.
13. Attach jamb brackets to verticals for 8, 9, 10 foot doors start with a #10 at lowest slotted hole, followed by a #12 then a #14, 7 foot tall doors will only have #10's and #12's (Figure 9) (leave loose for adjustment)
14. Remove rollers from hardware box and insert into bottom fixtures and extended roller locations (Figure 8) on end hinges of each section.
15. Just prior to attaching vertical track to h casing remove nails or "z" brackets on that side only.
16. Place half inch block below vertical track locations (If bottom edge of door was raised higher than 1/2" place equal sized block underneath track, So if the bottom edge of the door is 1" off of the ground to be level put one inch block underneath vertical track on that side.)
17. With assembled vertical track starting with right side rock track onto all rollers simultaneously "locking" rollers into track. (Figure 10)

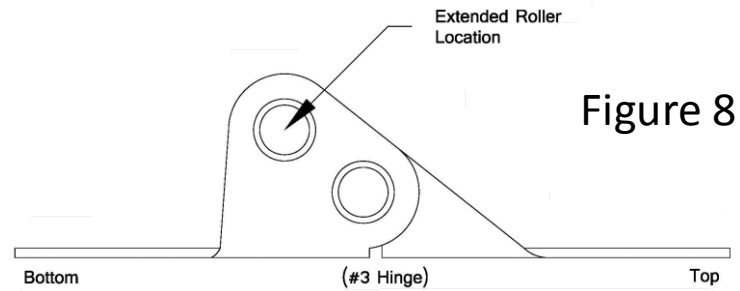

Figure 8

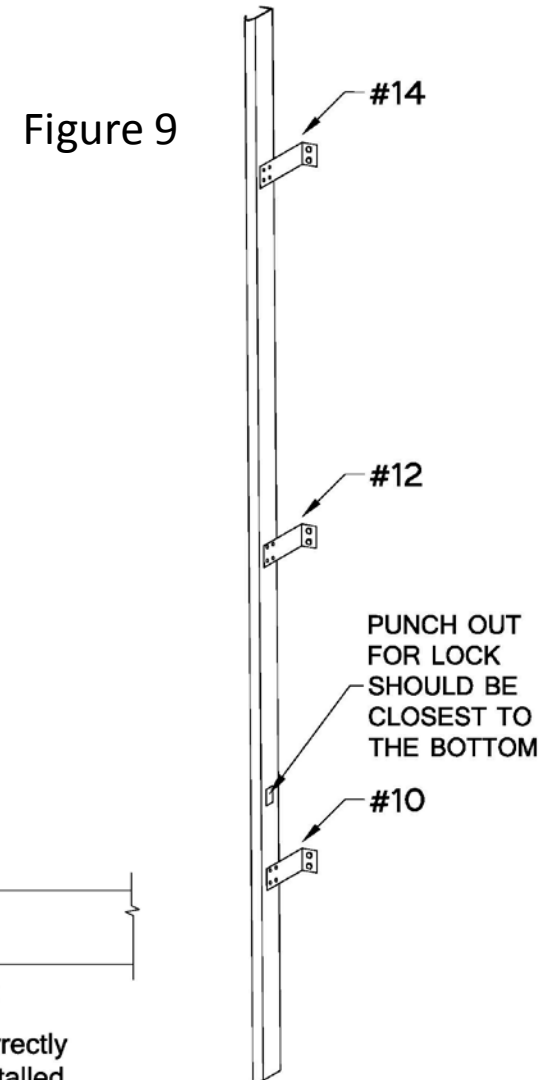
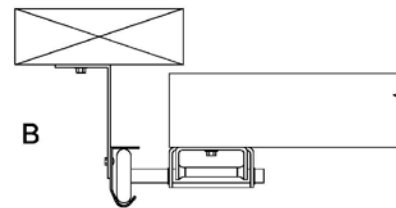
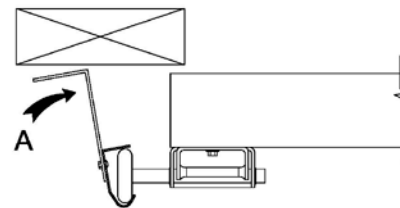

Figure 9



Correctly Installed

Figure 10

18. With bottom of vertical track placed $\frac{1}{8}$ " away from bottom corner of door. Set #10 jamb bracket against "H casing" pre drill and attach with provided lags.

19. Set the top of the vertical track $\frac{3}{4}$ " away from the edge of the door. Set #14 jamb bracket against "H casing". Pre-drill and attach with provided lags. (see Figure 11)

20. Set #12 jamb bracket against "H casing" where it lies. Pre-drill and attach with provided lags.

21. Remove right side flag bracket from hardware box. Attach to top of vertical in lower flag slot with 2 - $\frac{5}{16}$ " track bolts provided. Do not tighten, leave loose. (see Figure 12)

Tip: flag brackets should be installed with flag closest to door and mounting angle pointed away from door.

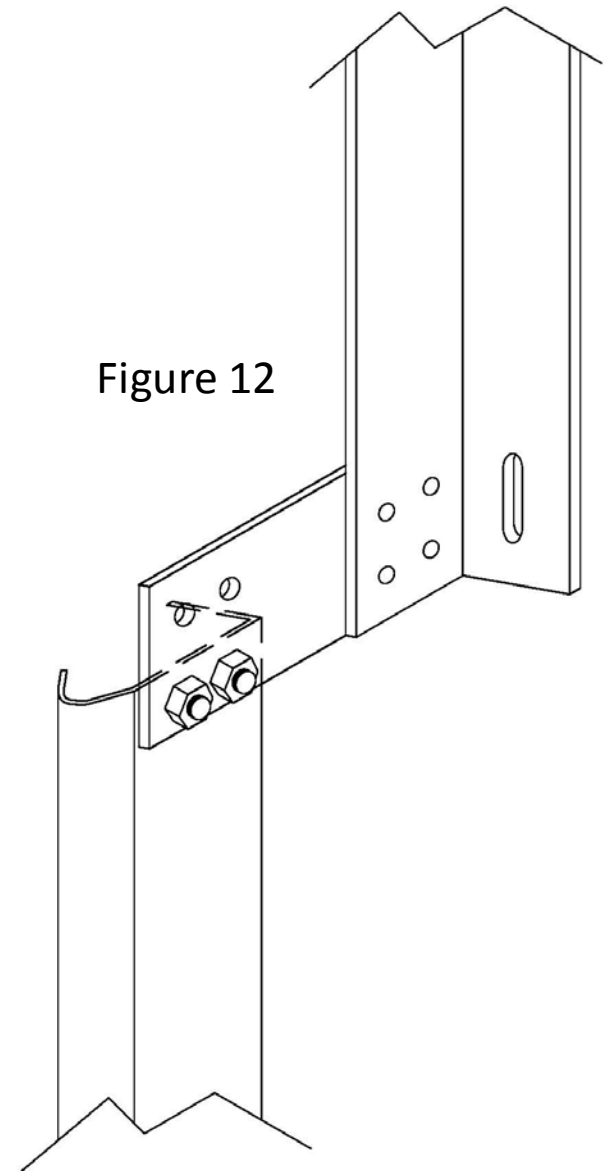
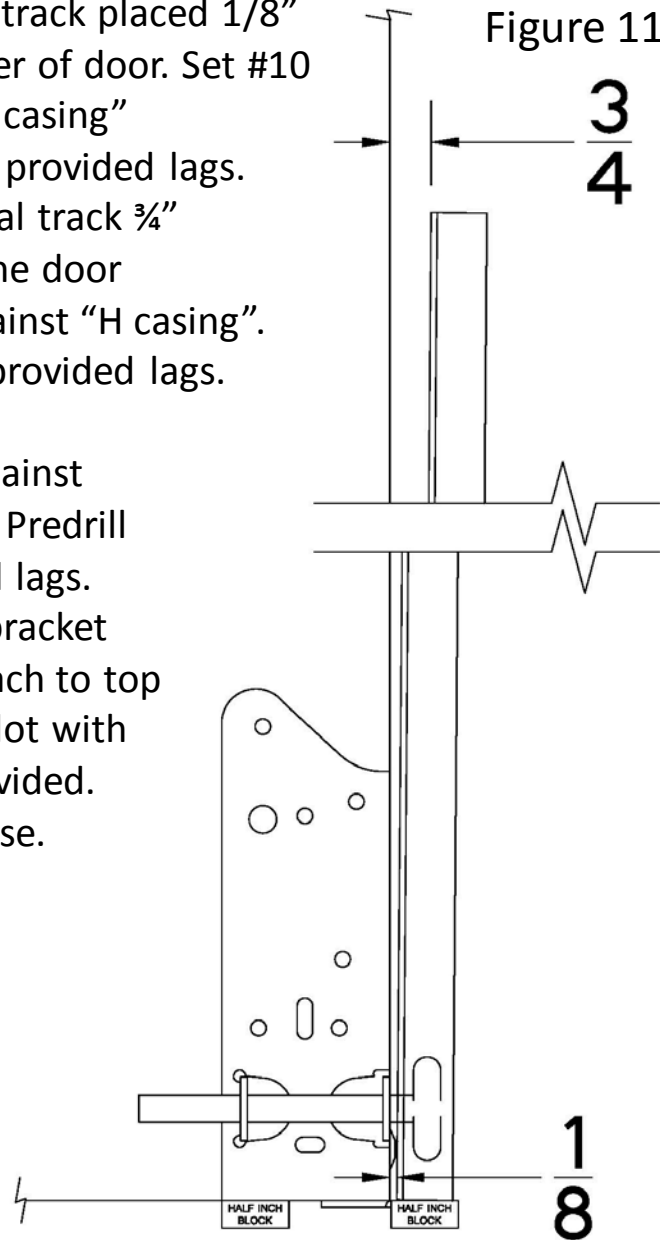

22. With flag bracket loosely attached to vertical, push flag bracket against “H casing” trying to keep as parallel to the door as possible. Predrill lowest horizontal slot on mounting angle of flag bracket and attach with provided lag loosely.

23. Place level vertically onto flag bracket once parallel predrill and attach at top horizontal slot on mounting angle of flag bracket.

Then sure and secure both top and bottom lags of flag bracket (leave vertical track loose for now)

24. While second person supports back of right side horizontal or “hooked” track. Place hook of track on top of vertical attach to flag bracket with 2 – 5/16” track bolts.

Then attach the support angle of the horizontal track to the top of the flag bracket using 1 – 9/16” carriage bolt with the nut to the outside.

25. While still supported by help, align rear of radius track with vertical and tighten all 4 track bolts (2 on the vertical and 2 on the “hook”)

26. Place level on horizontal track, once level tighten top 9/16” carriage bolt and the horizontal track should be supported enough to release at rear.

27. Remove right side bearing plate from hardware box. Using 2 - 9/16” carriage bolts attach bearing plate to horizontal track. With mounting angle flush against the jamb pointed away from the door. Then using 2 - 1/4” x 20 x 3” lags predrill and attach bearing plate to “H casing”.

(SEE Figure 13 for completed steps 22-26)

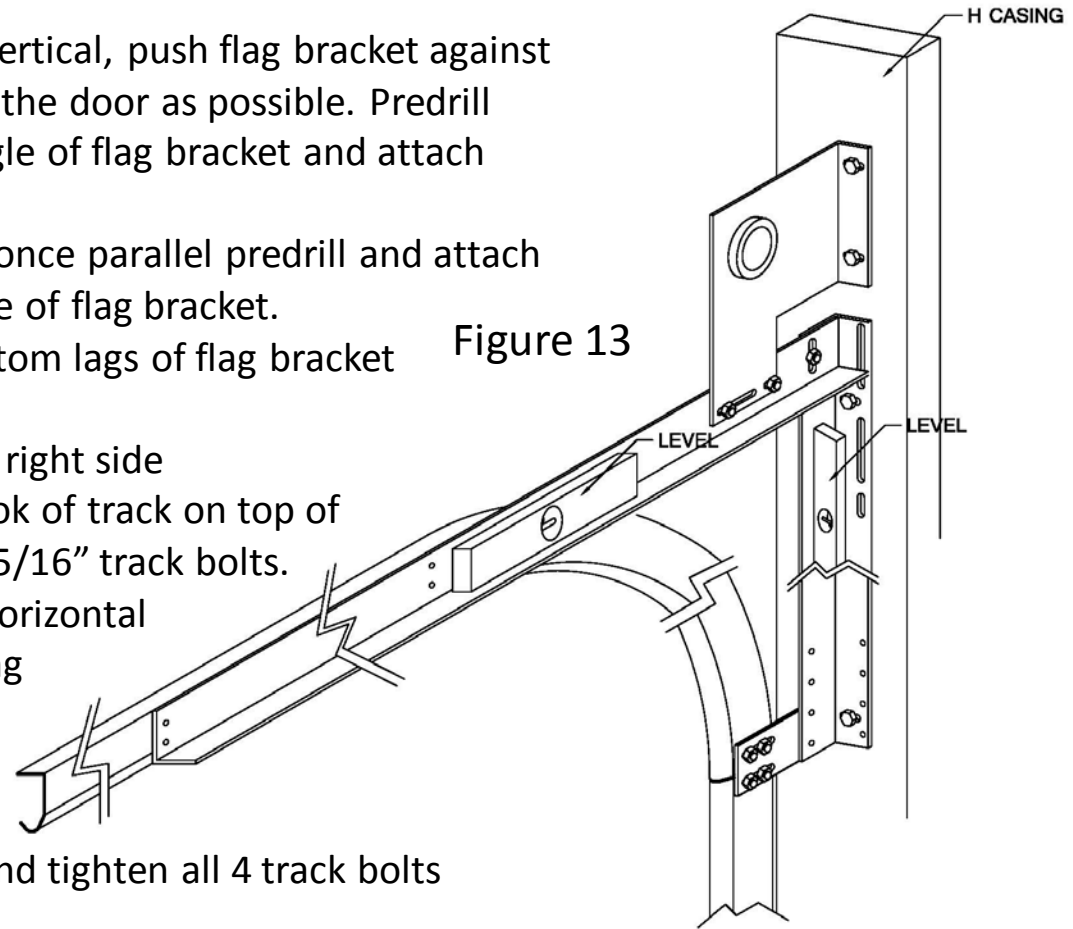

28. Remove top fixtures from hardware box, loosen adjustment plate with $\frac{1}{2}$ " wrench. Install roller into top fixture.
29. Measure 2" from top of door and mark, rock roller into radius of track. The roller should be on the top of the top fixture. Pre-drill and install top of top fixture two inches from top of door flush with edge. With all six anchor points using $\frac{1}{4}$ " x 20 x $1\frac{1}{4}$ " lags.
30. With eye or a shim pull top of door away from header slightly ($\frac{1}{8}$ ") then place $\frac{5}{16}$ " track bolt through available hole in top fixture and tighten $\frac{1}{2}$ " adjustment bolt. Then remove nail or "z" bracket holding the top section to the H-casing.
31. Making sure the door is not bound against the jamb tighten track bolts for the jamb brackets attached to the vertical.
32. Repeat steps 13 – 31 for left hand side.

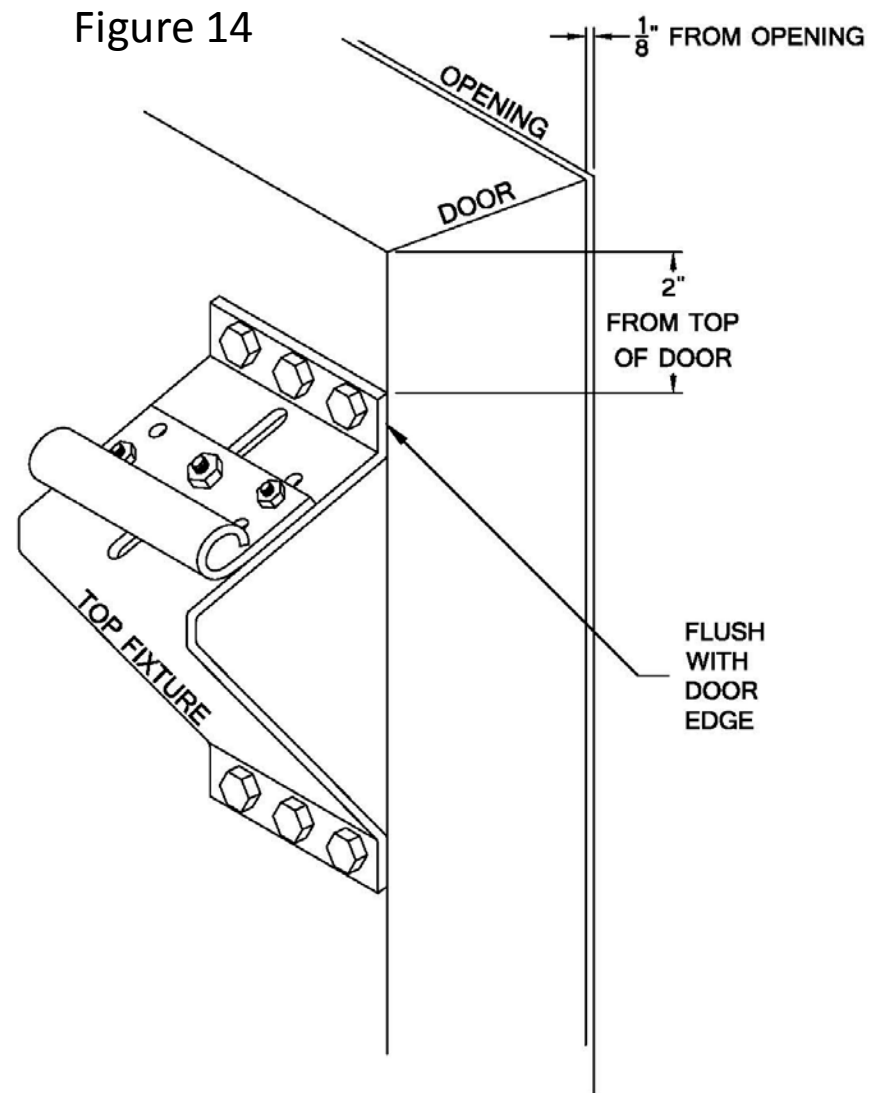

33. Cut and assemble 1"x1" punched angel (not included) for back hangs. (Figure 15)
34. Locate ceiling joists or upper floor trusses predrill and attach back hangs with 1/4" x 20 x 3" lags, making sure that track is level and parallel from wall measuring at front of horizontal to wall and to a similar location from wall to rear of horizontal attach back hang to track using 5/16" x 1" bolt. In some cases center hangs may be required. (A2 Figure 1)
35. Repeat steps 34-35 for left hand side
36. Starting with #1 (bottom) section, at bottom of the hinges that are attached between #1 and #2 section. Place top of strut 1/8" down from bottom of hinge centered in door. Predrill and attach using 1/4" x 20 x 1 1/4" lags. Repeats for all sections except for top. (Figure 16)
37. Strut for top section should be attached above the top fixtures in the manner described in step.

Note: all attachment points should be in line with FULL hinges on door. Some struts may have holes where hinges may not be do not attach strut in these locations.

Figure 15

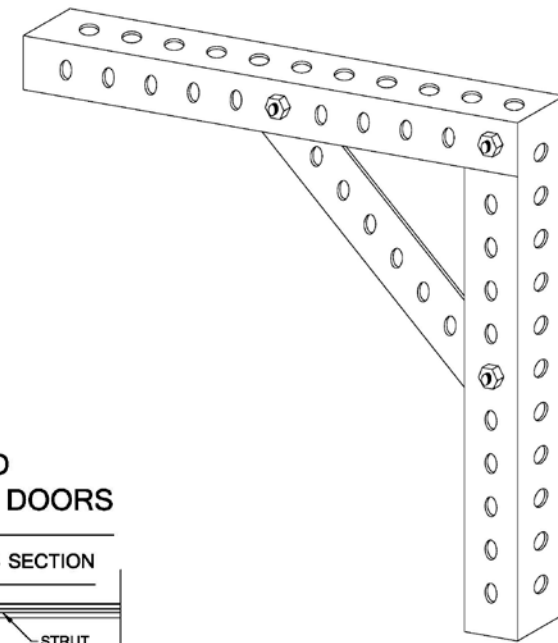

STANDARD
NON-WIND LOAD DOORS

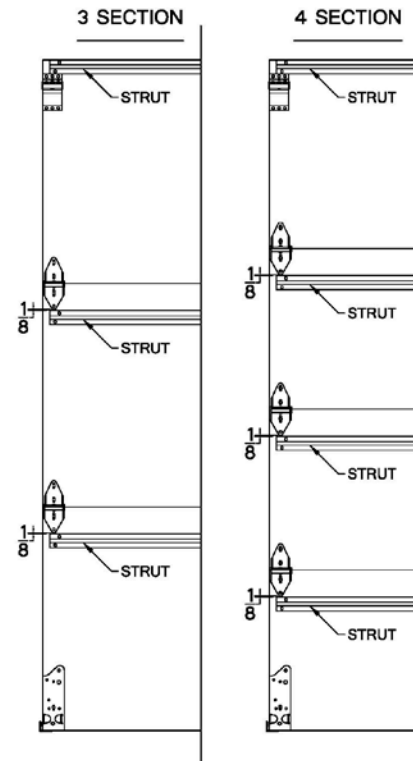

Figure 16

IMPORTANT: We recommend that you call a professional for the last step of the installation of this door, as it can cause serious bodily injury if not preformed correctly. Understand that you are continuing at your own risk.

38. Assemble torsion tube as pictured figure 17-21
39. With a friend lift torsion assembly above track. Slide one side of the tube into one bearing plate first to clear bearing plate on other side and then slide into other bearing plate.
40. Before attaching spring mounting brackets make sure to level torsion assembly. Pre drill and attach spring mounting brackets with 1/4" x 20 x 3" lags. Using no less than two per bracket.
41. Starting with left side attach cable from bottom fixture to drum running closest to the wall. Rotate drum until slack is removed from cable. Tighten set screws on drum. While holding tension on drum by rotating tube fix tube in place by attaching locking vise-grips so that handle rests against jamb.
42. On right side attach cable in same manner as left, remove slack from drum, and tighten set screws. No locking vise-grips needed for this side.

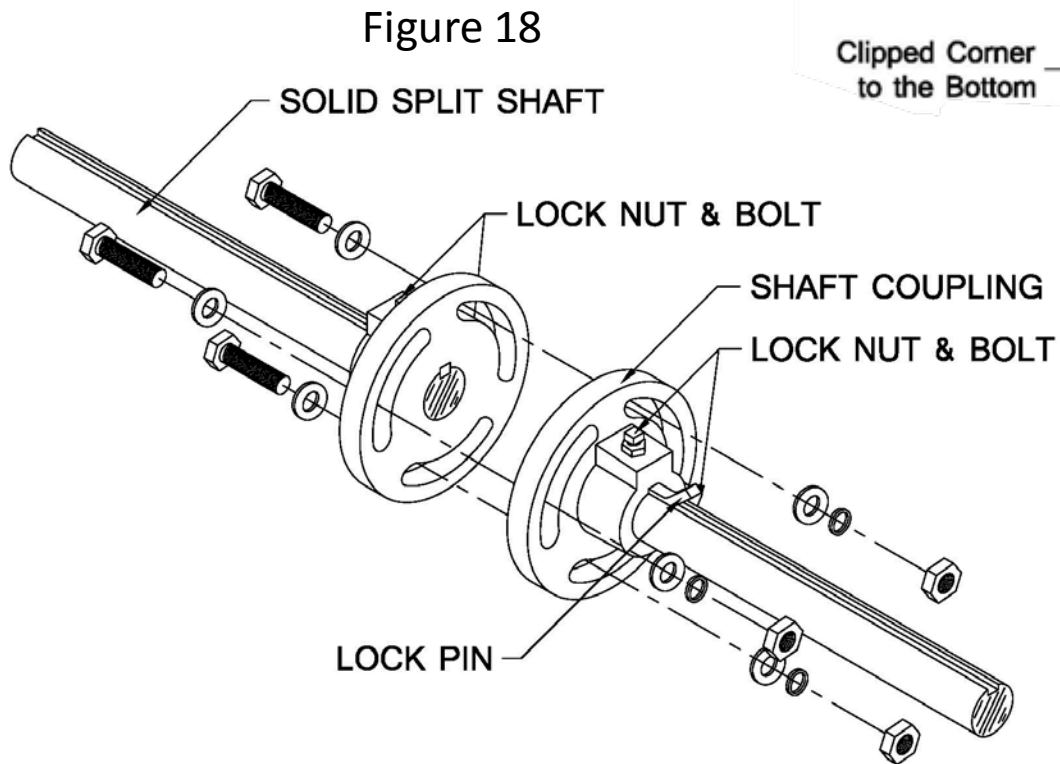
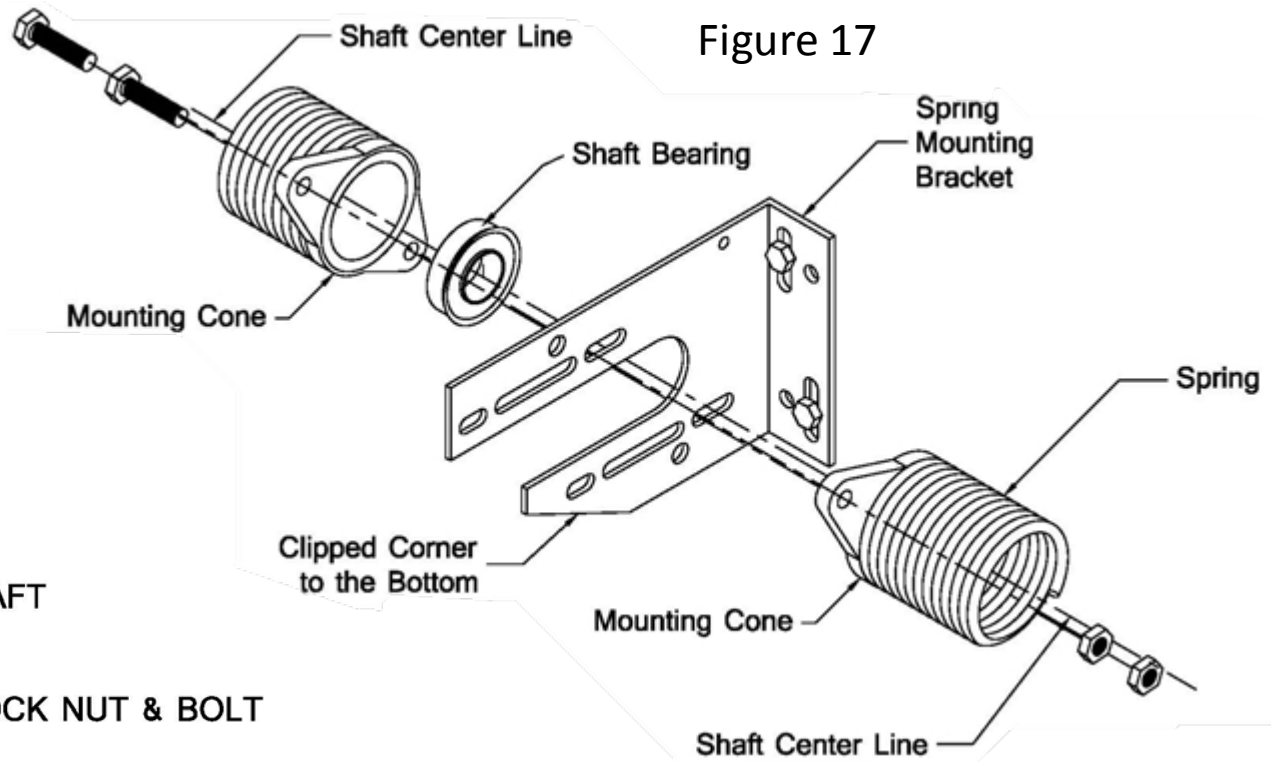
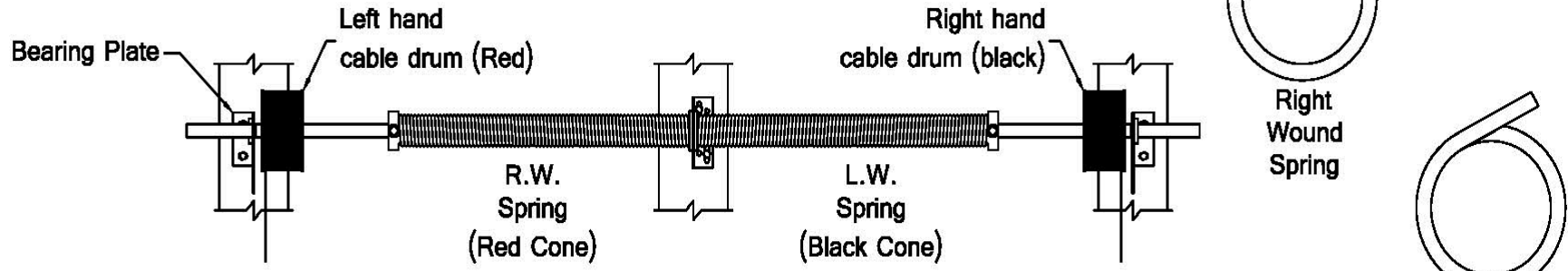
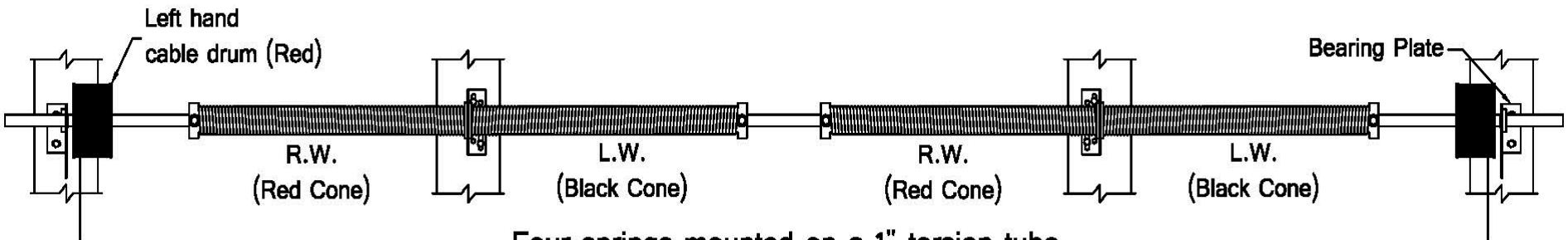

Figure 19



Two springs mounted on a 1" torsion tube.

Figure 20



Four springs mounted on a 1" torsion tube.

Figure 21

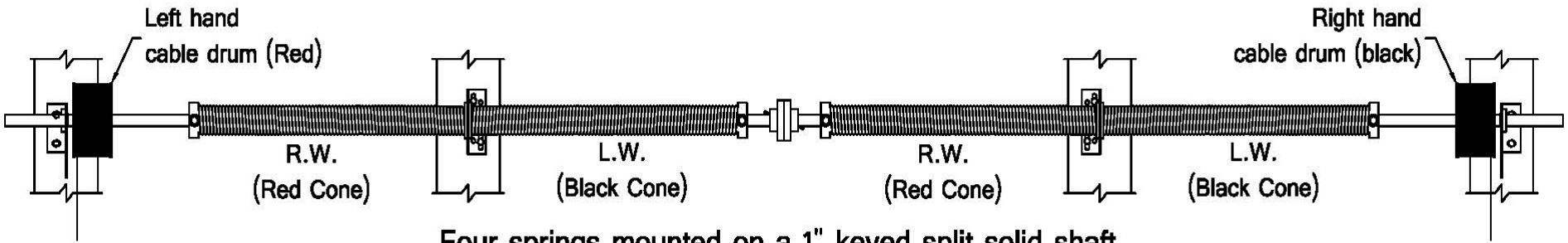

Four springs mounted on a 1" keyed split solid shaft.

REVISIONS

| ZONE | REV | DESCRIPTION | DATE | APPROVED |
|------|-----|-------------|------|----------|
| | | | | |

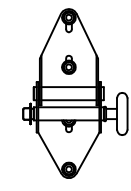
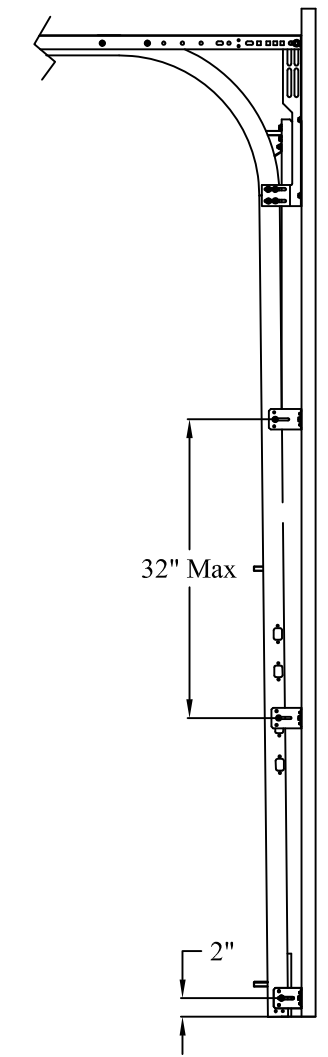
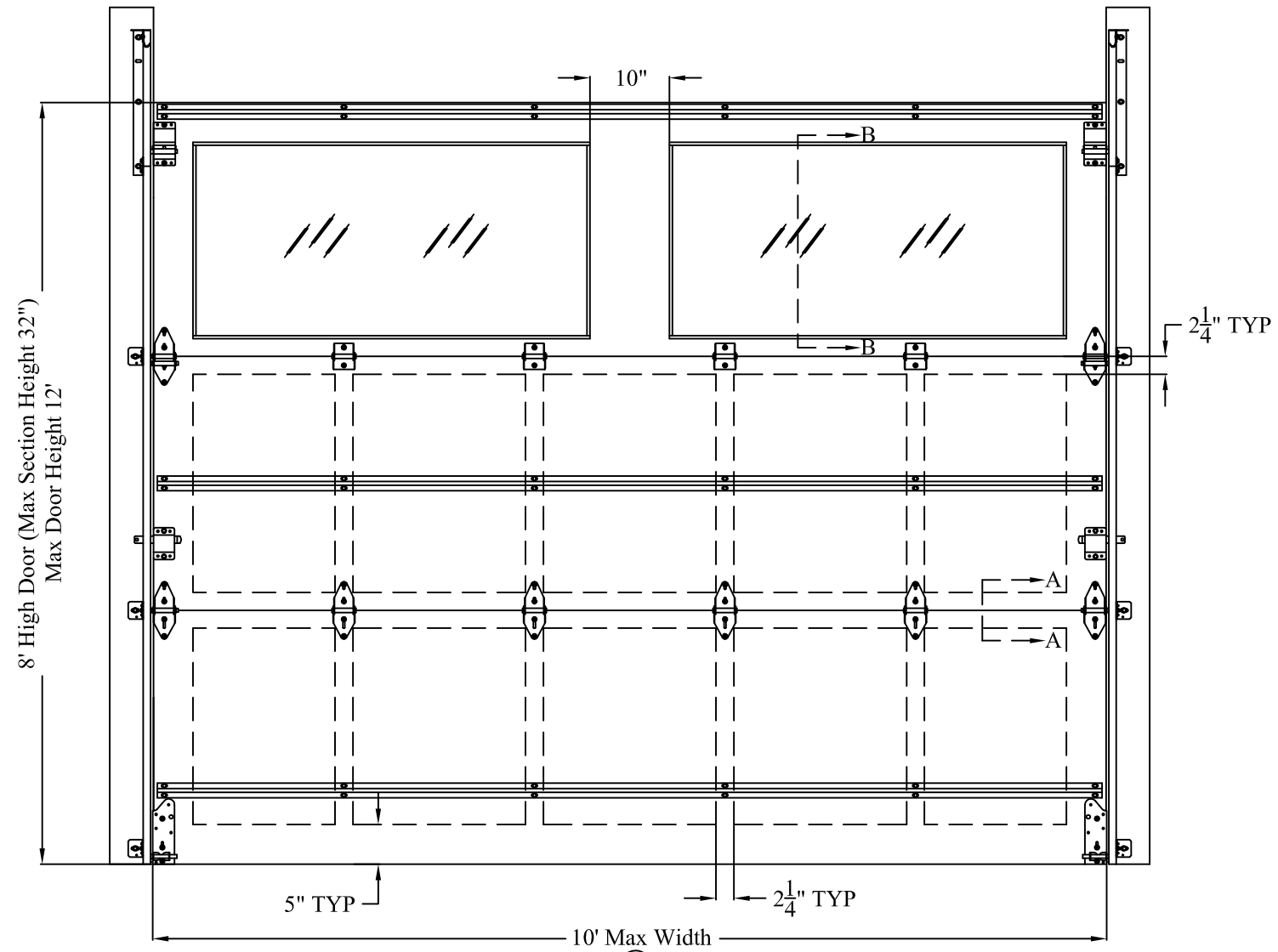

End Hinge
11 gauge galvanized steel end hinge attached with four 1/4\"/>

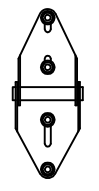

Center Hinge
11 gauge galvanized steel hinge at each center stile attached with four 1/4\"/>

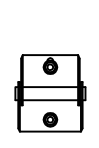

Short Center Hinge
11 gauge galvanized steel hinge at each center stile attached with two 1/4\"/>

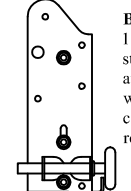

Bottom Bracket
11 gauge galvanized steel bottom bracket attached to bottom section with three 1/4\"/>

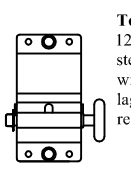

Top Fixture
12 gauge galvanized steel top fixture attached with two 1/4\"/>

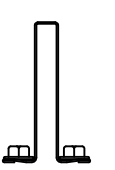

Struts
3\"/>

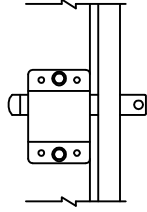

Locking Mechanism
Doors must have either an electronic operator or locking device installed (inside slide lock shown, other lock types permitted)

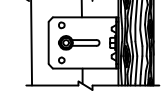

Track Brackets
12 gauge galvanized steel track bracket attached to wood jamb with one 5/16\"/>

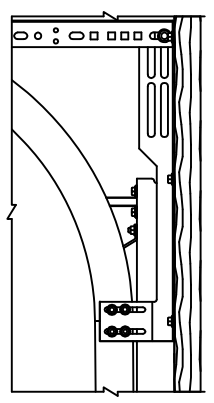

Flag Bracket
12 gauge galvanized steel flag bracket attached to wood jamb with three 5/16\"/>

Horizontal Track and Angle
Horizontal track and angle to suit

Vertical Track
2\"/>

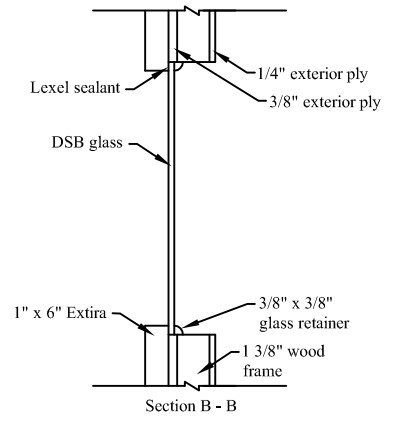
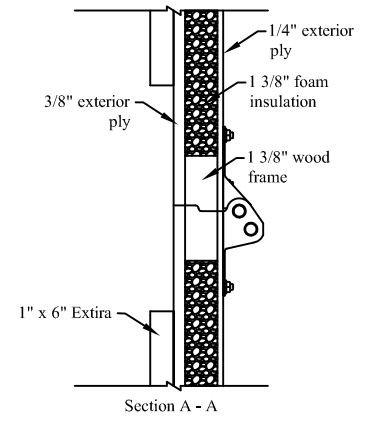

Windows (optional)
DSB glass windows with a maximum opening of 49 1/4\"/>

Note: The design of the supporting structural elements shall be the responsibility of the professional of record for the structure and in accordance with current building codes for the loads listed on this document

Models: Design 101 thru 108
Tested in accordance with ANSI/DASMA 108
Design Pressure: +37/-37 PSF
Test Pressure: +55.5/-55.5 PSF

DRAWN BY:
John M. Stroede 4/4/15

APPROVED BY:
John M. Stroede 4/4/15

Carriage House Door
 COMPANY
 1571 E. MAIN ST./HWY 79
 OLD FORT, NC 28762
 PHONE 828-668-1600
 FAX 828-668-1805

TITLE
10x8 Carriage House Door +37/-37 PSF

DRAWING NUMBER
Carriage-10-8-37-37

REVISION
A

SIZE B **SCALE** N/A **SHEET** 1 of 1

REVISIONS

| ZONE | REV | DESCRIPTION | DATE | APPROVED |
|------|-----|-------------|------|----------|
| | | | | |

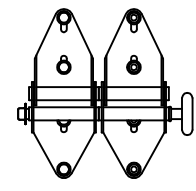
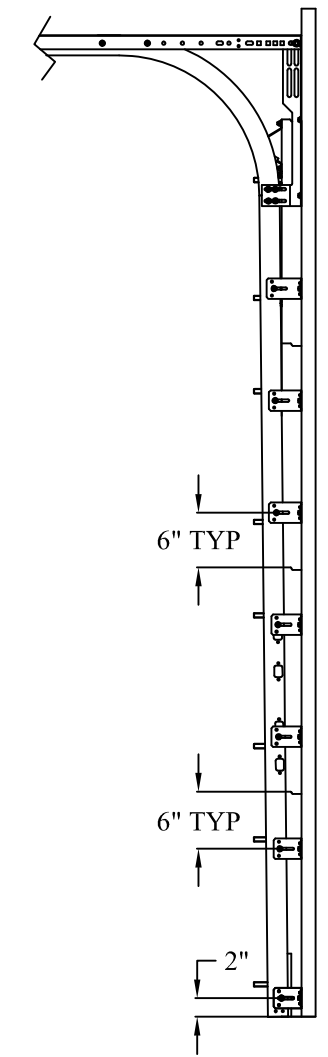
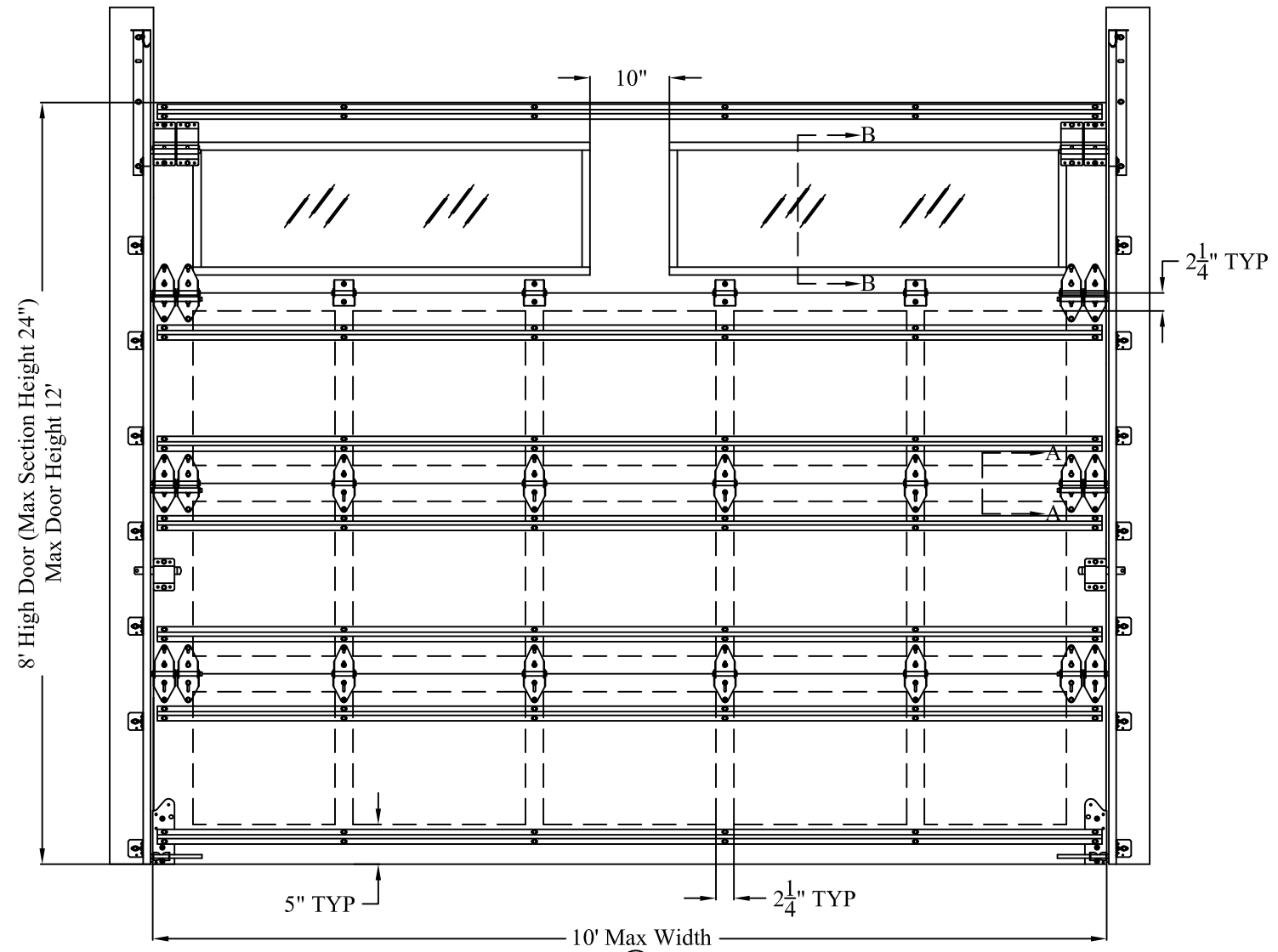

End Hinge
11 gauge galvanized steel double end hinges with the outer hinge attached with four 1/4" x 2 1/4" carriage bolts and the inner hinge attached with four 1/4" x 1 3/8" lag screws
Roller
2" steel or nylon roller with a hardened 7" stem and push nut installed (hurricane roller)

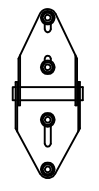

Center Hinge
11 gauge galvanized steel hinge at each center stile attached with four 1/4" x 2 1/4" carriage bolts

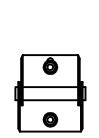

Short Center Hinge
11 gauge galvanized steel hinge at each center stile attached with two 1/4" x 2 1/4" carriage bolts (for use on glass section)

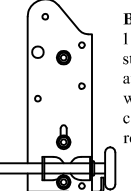

Bottom Bracket
11 gauge galvanized steel bottom bracket attached to bottom section with three 1/4" x 2 1/4" carriage bolts (no push nut required on bottom roller)

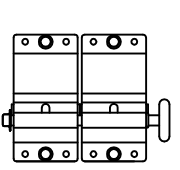

Top Fixture
12 gauge galvanized steel double top fixtures attached with two 1/4" x 1 3/8" lag screws each (push nut is required on top roller)

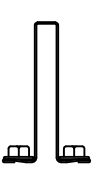

Struts
3" 20 gauge 50 ksi hat strut attached with two 1/4" x 1 3/8" lag screws per stile and located as shown on the sections

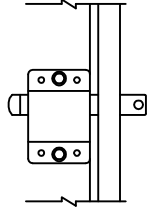

Locking Mechanism
Doors must have either an electronic operator or locking device installed (inside slide lock shown, other lock types permitted)

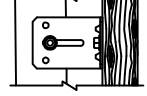

Track Brackets
12 gauge galvanized steel track bracket attached to wood jamb with one 5/16" x 3" wood lag screw and to vertical track with one 1/4" x 5/8" track bolt and nut

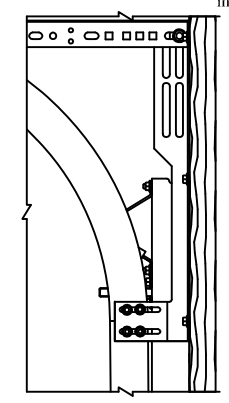

Flag Bracket
12 gauge galvanized steel flag bracket attached to wood jamb with three 5/16" x 3" wood lag screws and to the horizontal and vertical tracks with two 1/4" x 5/8" track bolts and nuts each

Horizontal Track and Angle
Horizontal track and angle to suit

Vertical Track
2" galvanized steel track with a minimum thickness of .075"

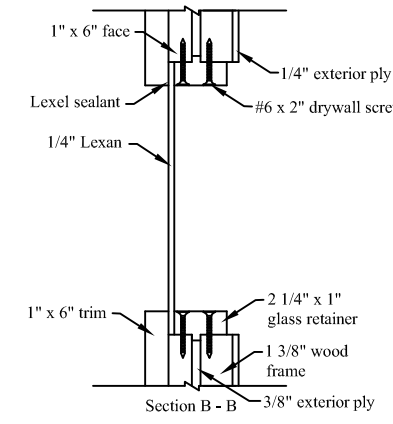
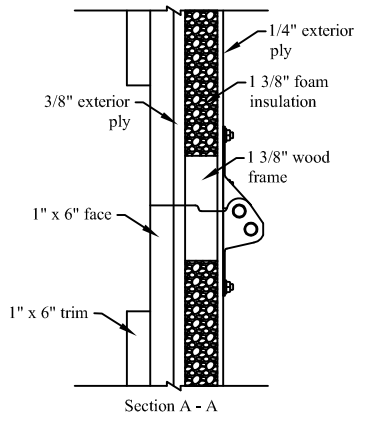

Windows (optional)
1/4" Lexan windows with a maximum opening of 49 1/4" x 16", retained on all four sides on the outside by 1" x 6" trim and on the inside by 1" x 2 1/4" retainer (overlap on all four sides is 1") screwed in with pairs of #6 x 2" drywall screws 1" from each edge and with a maximum spacing of 13", and sealed on all four edges with Lexel sealant

Note: The design of the supporting structural elements shall be the responsibility of the professional of record for the structure and in accordance with current building codes for the loads listed on this document

Models: Design 101 thru 108
Tested in accordance with ANSI/DASMA 108 and ANSI/DASMA 115
Design Pressure: +50/-57.5 PSF
Test Pressure: +75/-86.3 PSF

DRAWN BY:
John M. Stroede 4/4/15

APPROVED BY:
John M. Stroede 4/4/15

Carriage House Door
COMPANY
1571 E. MAIN ST./HWY 79
OLD FORT, NC 28762
PHONE 828-668-1600
FAX 828-668-1805

TITLE
10x8 Carriage House Door +50/-57.5 PSF

DRAWING NUMBER
Carriage-10-8-50-57

REVISION
A

SIZE B **SCALE** N/A **SHEET** 1 of 1

| REVISIONS | | | | |
|-----------|-----|-------------|------|----------|
| ZONE | REV | DESCRIPTION | DATE | APPROVED |
| | | | | |

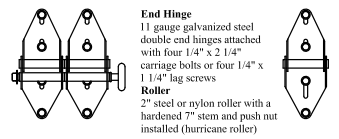
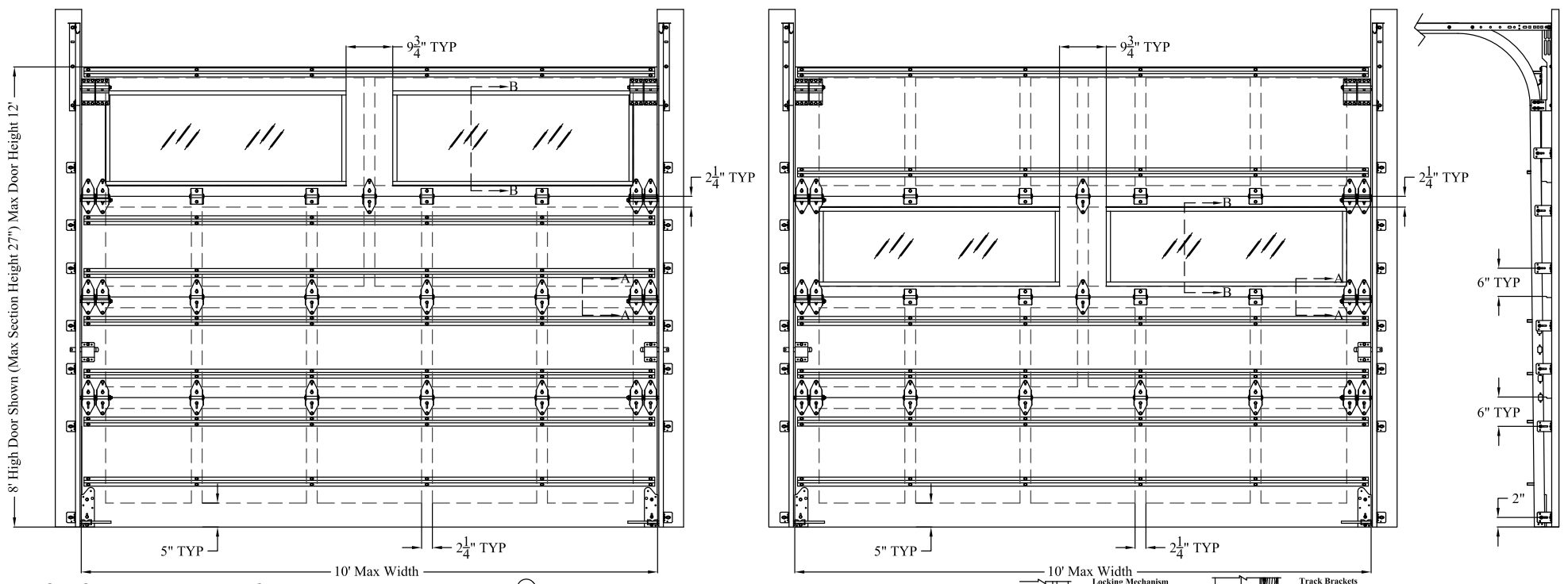

End Hinge
11 gauge galvanized steel double end hinges attached with four 1/4" x 2 1/4" carriage bolts or four 1/4" x 1 1/4" lag screws

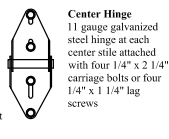

Center Hinge
11 gauge galvanized steel hinge at each center stile attached with four 1/4" x 2 1/4" carriage bolts or four 1/4" x 1 1/4" lag screws

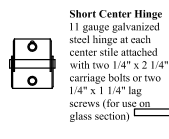

Short Center Hinge
11 gauge galvanized steel hinge at each center stile attached with two 1/4" x 2 1/4" carriage bolts or two 1/4" x 1 1/4" lag screws

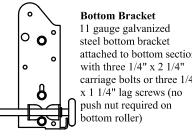

Bottom Bracket
11 gauge galvanized steel bottom bracket attached to bottom section with three 1/4" x 2 1/4" carriage bolts or three 1/4" x 1 1/4" lag screws (no push nut required on bottom roller)

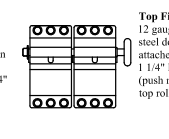

Top Fixture
12 gauge galvanized steel double top fixtures attached with six 1/4" x 1 1/4" lag screws each (push nut is required on top roller)

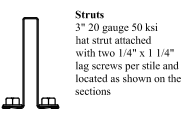

Struts
3" 20 gauge 50 ksi lat strut attached with two 1/4" x 1 1/4" lag screws per stile and located as shown on the sections

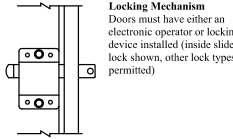

Locking Mechanism
Doors must have either an electronic operator or locking device installed (inside slide lock shown, other lock types permitted)

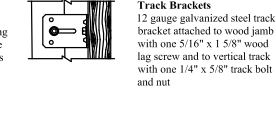

Track Brackets
12 gauge galvanized steel track bracket attached to wood jamb with one 5/16" x 1 5/8" wood lag screw and to vertical track with one 1/4" x 5/8" track bolt and nut

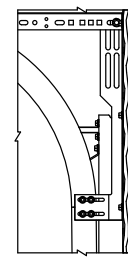

Flag Bracket
12 gauge galvanized steel flag bracket attached to wood jamb with three 5/16" x 1 5/8" wood lag screws and to the horizontal and vertical tracks with two 1/4" x 5/8" track bolts and nuts each

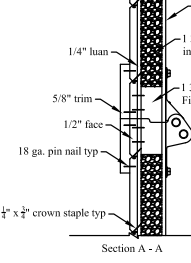

Horizontal Track and Angle
Horizontal track and angle to suit

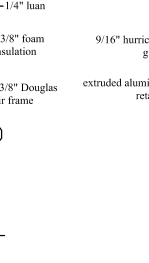

Vertical Track
2" galvanized steel track with a minimum thickness of .083"

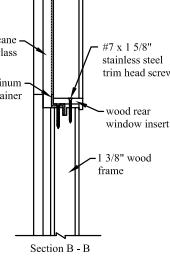

Section A - A

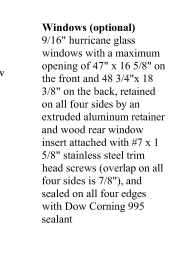

Section B - B

Windows (optional)
9/16" hurricane glass windows with a maximum opening of 47" x 16 5/8" on the front and 48 3/4" x 18 3/8" on the back, retained on all four sides by an extruded aluminum retainer and wood rear window insert attached with #7 x 1 5/8" stainless steel trim head screws (overlap on all four sides is 7/8"), and sealed on all four edges with Dow Corning 995 sealant

Note: The design of the supporting structural elements shall be the responsibility of the professional of record for the structure and in accordance with current building codes for the loads listed on this document

Models: Design 101 thru 108
Tested in accordance with ANSI/DASMA 108 and ANSI/DASMA 115
Design Pressure: +48/-55 PSF
Test Pressure: +72/-82.5 PSF

DRAWN BY:
John M. Stroede 6/5/18
APPROVED BY:
John M. Stroede 6/5/18

15711 MAIN ST HWY 19
OLD FORT, NC 28762

PHONE 828-668-1600
FAX 828-668-1805

TITLE
10x8 Carriage House Door +48/-55 PSF

| | |
|--|----------------------|
| DRAWING NUMBER Carriage-10-8-48-55 | REVISION A |
| SIZE B | SCALE N/A |
| SHEET 1 of 1 | |

| REVISIONS | | | | |
|-----------|-----|-------------|------|----------|
| ZONE | REV | DESCRIPTION | DATE | APPROVED |
| | | | | |

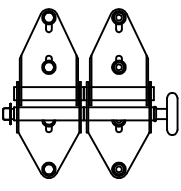
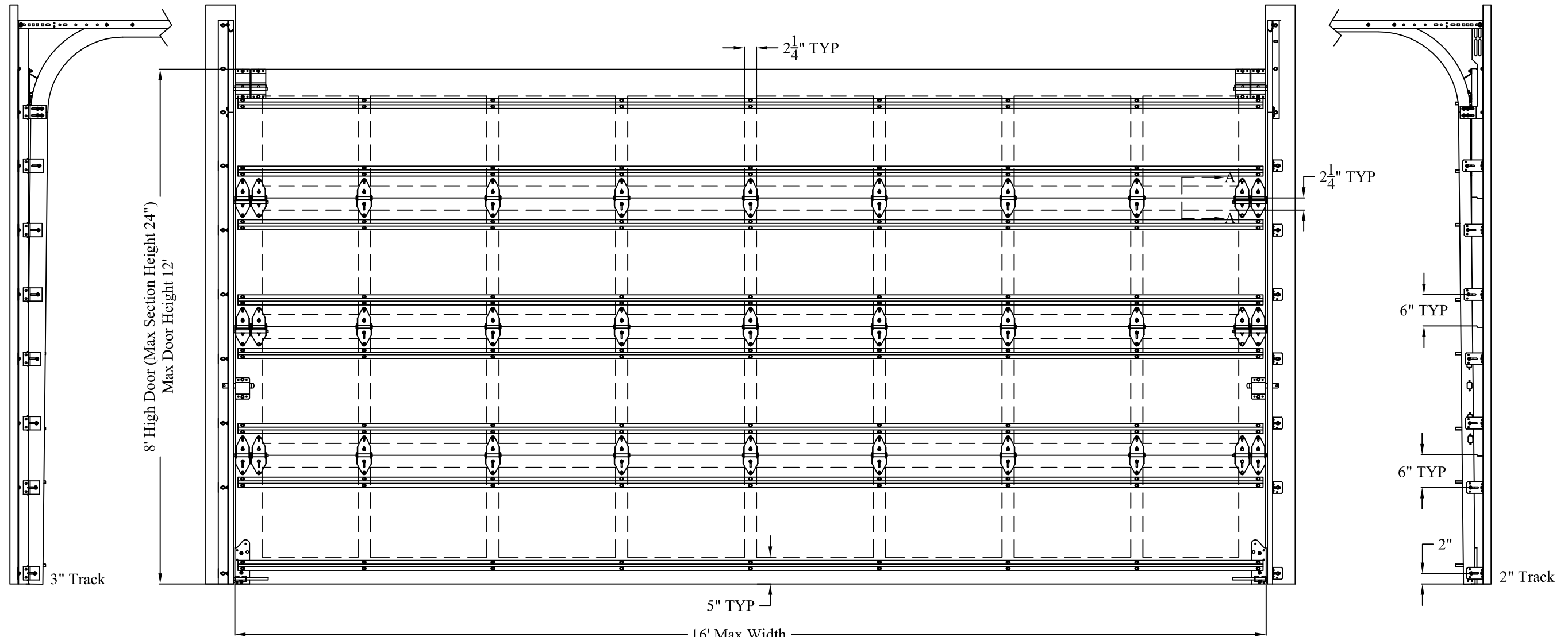

End Hinge
11 gauge galvanized steel double end hinges with the outer hinge attached with four 1/4" x 2 1/4" carriage bolts and the inner hinge attached with four 1/4" x 1 3/8" lag screws

Roller
2" or 3" steel or nylon roller with a hardened 7" stem and push nut installed (hurricane roller)

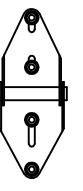

Center Hinge
11 gauge galvanized steel hinge at each center stile attached with four 1/4" x 2 1/4" carriage bolts

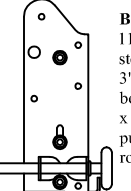

Bottom Bracket
11 gauge galvanized steel bottom bracket for 2" or 3" rollers and attached to bottom section with three 1/4" x 2 1/4" carriage bolts (no push nut required on bottom roller)

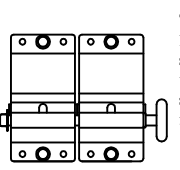

Top Fixture
12 gauge galvanized steel double top fixtures two 1/4" x 1 3/8" lag screws each (push nut is required on top roller)

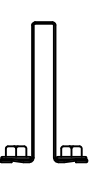

Struts
3" 20 gauge 50 ksi hat strut attached with two 1/4" x 1 3/8" lag screws per stile and located as shown on the sections (two per section)

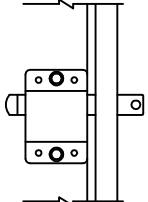

Locking Mechanism
Doors must have either an electronic operator or locking device installed (inside slide lock shown, other lock types permitted)

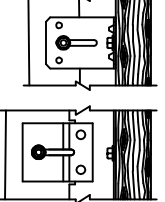

Track Brackets and Clips
12 gauge galvanized steel track bracket attached to wood jamb with one 5/16" x 3" wood lag screw and to vertical track with one 1/4" x 5/8" track bolt and nut or 12 gauge galvanized steel track clips riveted to 12 gauge angle (the same spacings apply to both track brackets and track clips)

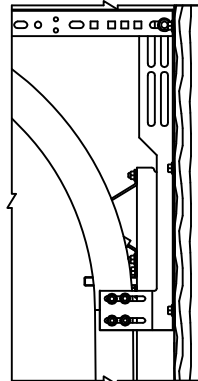

2" Track Option

Flag Bracket
12 gauge galvanized steel flag bracket attached to wood jamb with three 5/16" x 3" wood lag screws and to the horizontal and vertical tracks with two 1/4" x 5/8" track bolts and nuts each

Horizontal Track and Angle
Horizontal track and angle to suit

Vertical Track
2" galvanized steel track with a minimum thickness of .075"

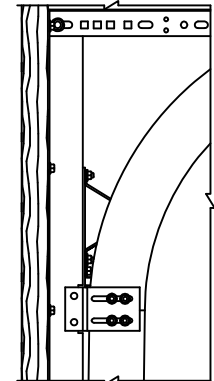

3" Track Option

Vertical Angle
12 gauge galvanized steel angle attached to wood jamb with 5/16" x 3" wood lag screws at each track clip location as well as one near the top of the door and one near the top of the vertical angle

Horizontal Track and Angle
Horizontal track and angle to suit

Vertical Track
3" galvanized steel track with a minimum thickness of .090"

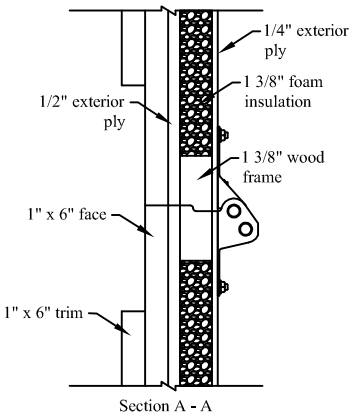

Note: The design of the supporting structural elements shall be the responsibility of the professional of record for the structure and in accordance with current building codes for the loads listed on this document

Models: Design 201, 202, 203, 206
Tested in accordance with ANSI/DASMA 108 and ANSI/DASMA 115
Design Pressure: +40/-43 PSF
Test Pressure: +60/-64.5 PSF
DRAWN BY:
John M. Stroede 4/4/15
APPROVED BY:
John M. Stroede 4/4/15

Carriage House Door
COMPANY

1571 E. MAIN ST./HWY 79
OLD FORT, NC 28762

PHONE 828-668-1600
FAX 828-668-1805

| | | | |
|--------------------------------------|--------------|-----------------|---------------|
| TITLE | | REVISION | |
| 16x8 Carriage House Door +40/-43 PSF | | A | |
| DRAWING NUMBER | | REVISION | |
| Carriage-16-8-40-43 | | A | |
| SIZE | SCALE | SHEET | 1 of 1 |
| B | N/A | | |

| REVISIONS | | | | |
|-----------|-----|-------------|------|----------|
| ZONE | REV | DESCRIPTION | DATE | APPROVED |
| | | | | |

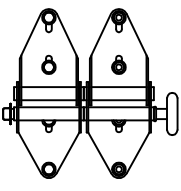
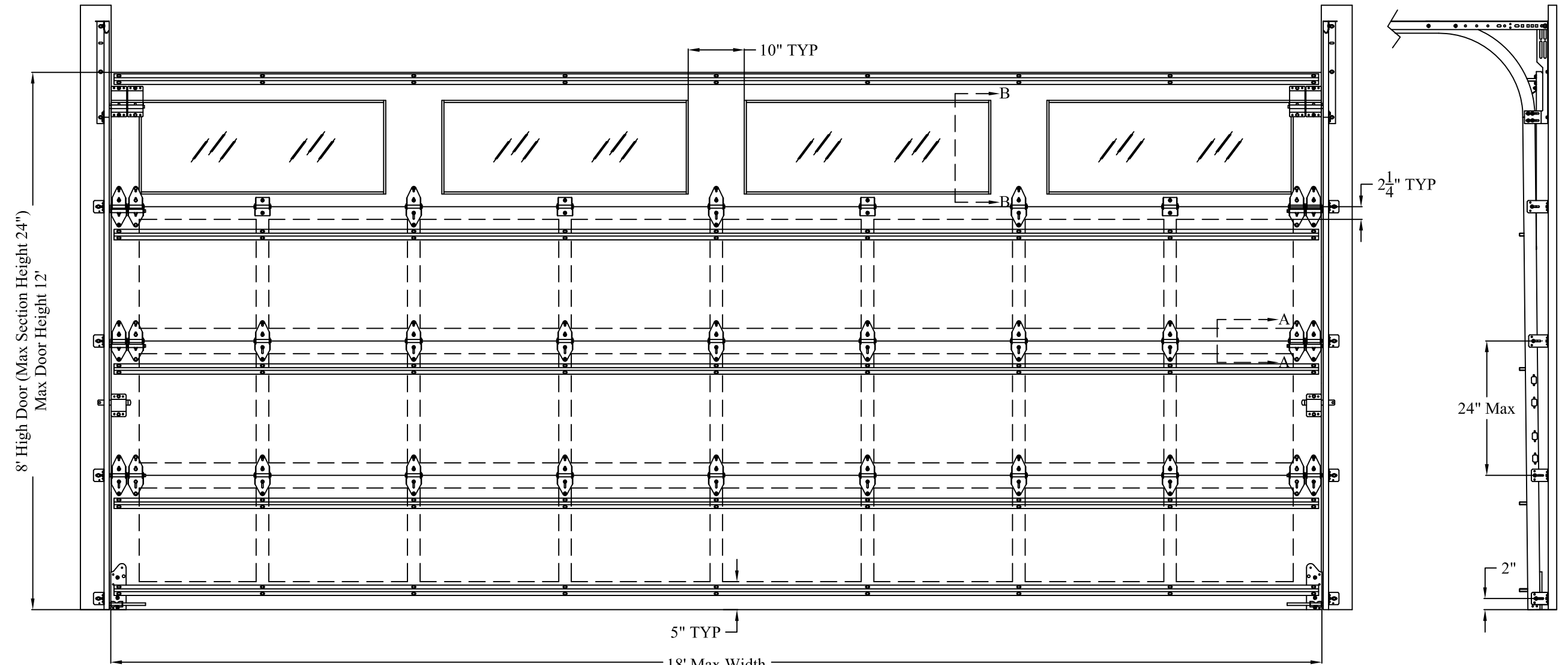

End Hinge
11 gauge galvanized steel double end hinges with the outer hinge attached with four 1/4" x 2 1/4" carriage bolts and the inner hinge attached with four 1/4" x 1 3/8" lag screws

Roller
2" steel or nylon roller with a hardened 7" stem and push nut installed (hurricane roller)

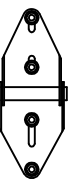

Center Hinge
11 gauge galvanized steel hinge at each center stile attached with four 1/4" x 2 1/4" carriage bolts



Short Center Hinge
11 gauge galvanized steel hinge at each center stile attached with two 1/4" x 2 1/4" carriage bolts (for use on glass section)

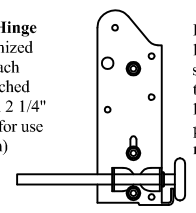

Bottom Bracket
11 gauge galvanized steel bottom bracket attached to bottom section with three 1/4" x 2 1/4" carriage bolts (no push nut required on bottom roller)

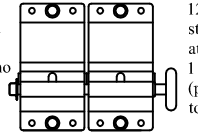

Top Fixture
12 gauge galvanized steel double top fixtures attached with two 1/4" x 1 3/8" lag screws each (push nut is required on top roller)

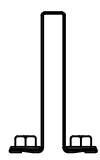

Struts
3" 20 gauge 50 ksi hat strut attached with two 1/4" x 1 3/8" lag screws per stile and located as shown on the sections (two per section)

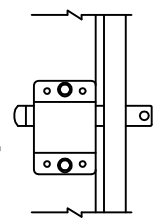

Locking Mechanism
Doors must have either an electronic operator or locking device installed (inside slide lock shown, other lock types permitted)

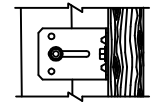

Track Brackets
12 gauge galvanized steel track bracket attached to wood jamb with one 5/16" x 3" wood lag screw and to vertical track with one 1/4" x 5/8" track bolt and nut

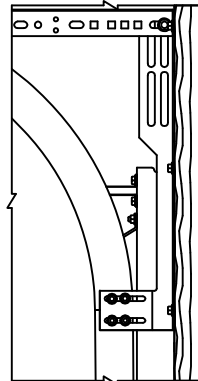

Flag Bracket
12 gauge galvanized steel flag bracket attached to wood jamb with three 5/16" x 3" wood lag screws and to the horizontal and vertical tracks with two 1/4" x 5/8" track bolts and nuts each

Horizontal Track and Angle
Horizontal track and angle to suit

Vertical Track
2" galvanized steel track with a minimum thickness of .075"

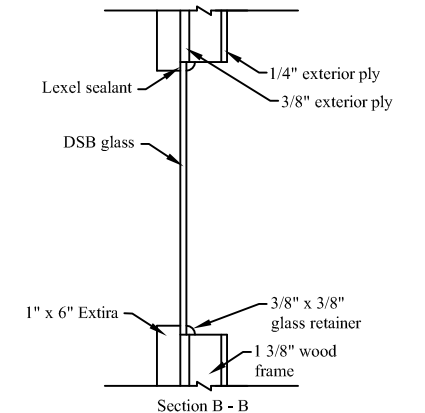
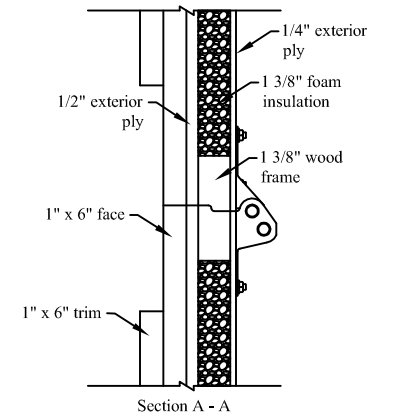

Windows (optional)
DSB glass windows with a maximum opening of 43 1/4" x 16", retained on all four sides on the outside by 1" x 6" Extrusion and on the inside by 3/8" x 3/8" quarter round retainer (overlap on all four sides 3/8") nailed in with 23 ga. x 5/8" pin nails 1" from each edge and with a maximum spacing of 6", and sealed on all four edges with Lexel sealant

Note: The design of the supporting structural elements shall be the responsibility of the professional of record for the structure and in accordance with current building codes for the loads listed on this document

Models: Design 101-108, 201-203
Tested in accordance with ANSI/DASMA 108
Design Pressure: +21/-21 PSF
Test Pressure: +31.5/-31.5 PSF
DRAWN BY:
John M. Stroede 4/4/15
APPROVED BY:
John M. Stroede 4/4/15

1571 E. MAIN ST./HWY 79
OLD FORT, NC 28762

PHONE 828-668-1600
FAX 828-668-1805

| | | | |
|--------------------------------------|--------------|-----------------|---------------|
| TITLE | | REVISION | |
| 18x8 Carriage House Door +21/-21 PSF | | A | |
| DRAWING NUMBER | | REVISION | |
| Carriage-18-8-21-21 | | A | |
| SIZE | SCALE | SHEET | 1 of 1 |
| B | N/A | | |

| REVISIONS | | | | |
|-----------|-----|-------------|------|----------|
| ZONE | REV | DESCRIPTION | DATE | APPROVED |
| | | | | |

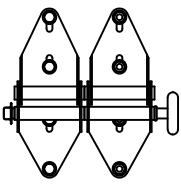
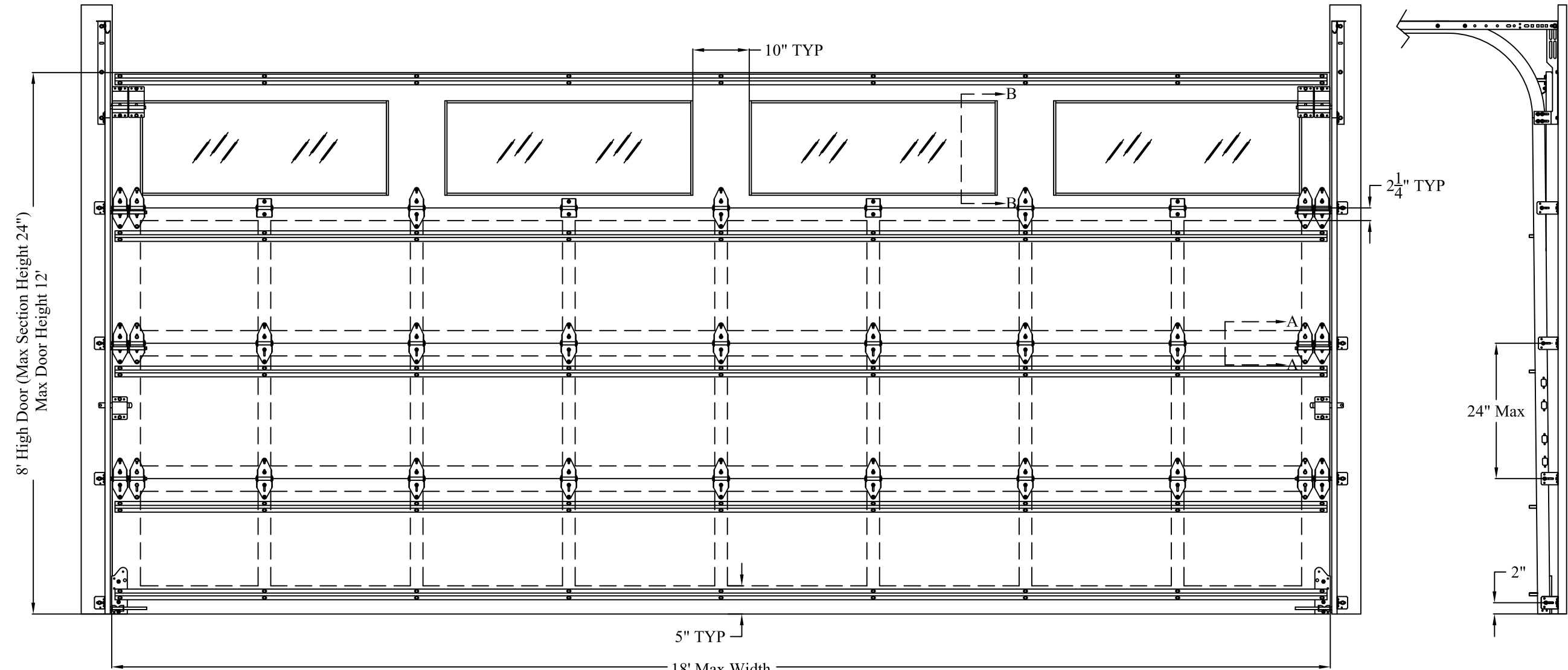

End Hinge
11 gauge galvanized steel double end hinges with the outer hinge attached with four 1/4" x 2 1/4" carriage bolts and the inner hinge attached with four 1/4" x 1 3/8" lag screws

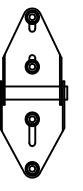

Center Hinge
11 gauge galvanized steel hinge at each center stile attached with four 1/4" x 2 1/4" carriage bolts

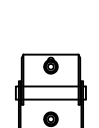

Short Center Hinge
11 gauge galvanized steel hinge at each center stile attached with two 1/4" x 2 1/4" carriage bolts (for use on glass section)

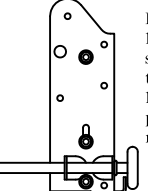

Bottom Bracket
11 gauge galvanized steel bottom bracket attached to bottom section with three 1/4" x 2 1/4" carriage bolts (no push nut required on bottom roller)

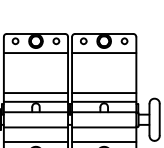

Top Fixture
12 gauge galvanized steel double top fixtures attached with two 1/4" x 1 3/8" lag screws each (push nut is required on top roller)

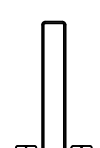

Struts
3" 20 gauge 50 ksi hat strut attached with two 1/4" x 1 3/8" lag screws per stile and located as shown on the sections (two per section)

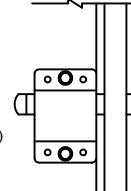

Locking Mechanism
Doors must have either an electronic operator or locking device installed (inside slide lock shown, other lock types permitted)

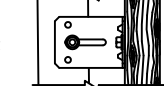

Track Brackets
12 gauge galvanized steel track bracket attached to wood jamb with one 5/16" x 3" wood lag screw and to vertical track with one 1/4" x 5/8" track bolt and nut

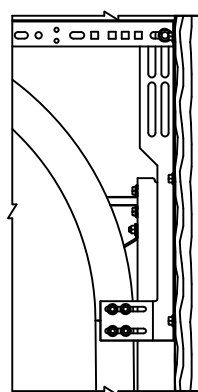

Flag Bracket
12 gauge galvanized steel flag bracket attached to wood jamb with three 5/16" x 3" wood lag screws and to the horizontal and vertical tracks with two 1/4" x 5/8" track bolts and nuts each

Horizontal Track and Angle
Horizontal track and angle to suit

Vertical Track
2" galvanized steel track with a minimum thickness of .075"

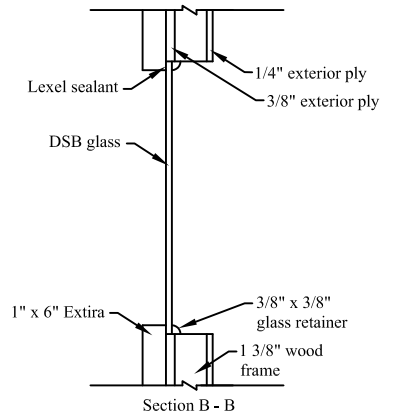
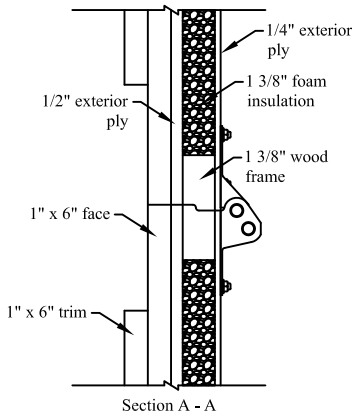

Windows (optional)
DSB glass windows with a maximum opening of 43 1/4" x 16", retained on all four sides on the outside by 1" x 6" Extrira and on the inside by 3/8" x 3/8" quarter round retainer (overlap on all four sides 3/8") nailed in with 23 ga. x 5/8" pin nails 1" from each edge and with a maximum spacing of 6", and sealed on all four edges with Lexel sealant

Note: The design of the supporting structural elements shall be the responsibility of the professional of record for the structure and in accordance with current building codes for the loads listed on this document

Models: Design 101-108, 201-203
Tested in accordance with ASTM E330 and ANSI/DASMA 108
Design Pressure: +25.5/-25.5 PSF
Test Pressure: +38.25/-38.25 PSF

DRAWN BY:
John M. Stroede 4/4/15

APPROVED BY:
John M. Stroede 4/4/15

Carriage House Door
COMPANY
1571 E. MAIN ST./HWY 79
OLD FORT, NC 28762
PHONE 828-668-1600
FAX 828-668-1805

| | | | |
|--|--------------|-----------------|---------------|
| TITLE | | REVISION | |
| 18x8 Carriage House Door +25.5/-25.5 PSF | | A | |
| DRAWING NUMBER | | REVISION | |
| Carriage-18-8-25-25 | | A | |
| SIZE | SCALE | SHEET | 1 of 1 |
| B | N/A | | |

| REVISIONS | | | | |
|-----------|-----|-------------|------|----------|
| ZONE | REV | DESCRIPTION | DATE | APPROVED |
| | | | | |

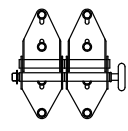
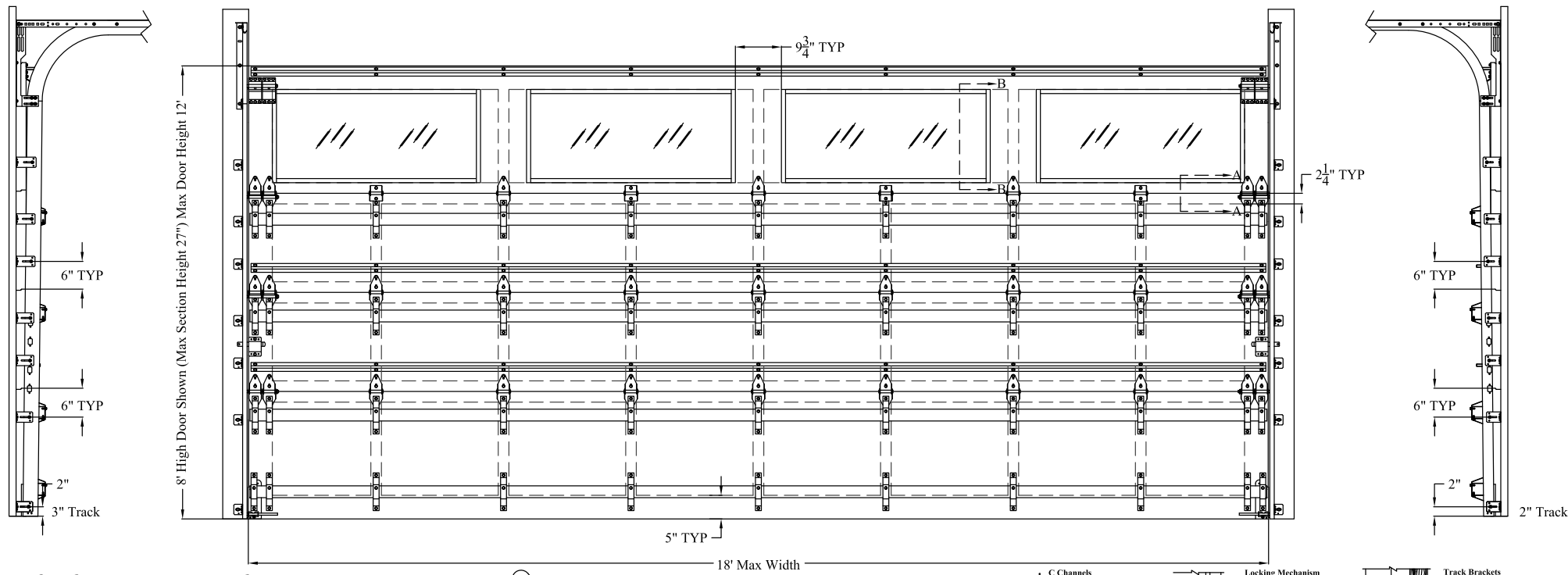

End Hinge
11 gauge galvanized steel double end hinges attached with four 1/4" x 2 1/4" carriage bolts or four 1/4" x 1 1/4" lag screws
2" steel or nylon roller with a hardened 7" stem and push nut installed (hurricane roller)

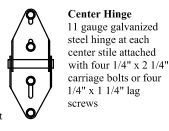

Center Hinge
11 gauge galvanized steel hinge at each center stile attached with four 1/4" x 2 1/4" carriage bolts or four 1/4" x 1 1/4" lag screws

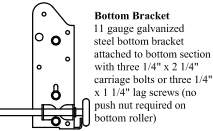

Short Center Hinge
11 gauge galvanized steel hinge at each center stile attached with two 1/4" x 2 1/4" carriage bolts or two 1/4" x 1 1/4" lag screws (for use on glass section)

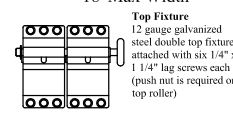

Bottom Bracket
11 gauge galvanized steel bottom bracket attached to bottom section with three 1/4" x 2 1/4" carriage bolts or three 1/4" x 1 1/4" lag screws (no push nut required on bottom roller)

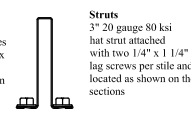

Top Fixture
12 gauge galvanized steel double top fixtures attached with six 1/4" x 1 1/4" lag screws each (push nut is required on top roller)

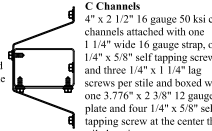

Struts
2" 20 gauge 80 ksi hat strut attached with two 1/4" x 1 1/4" lag screws per stile and located as shown on the sections

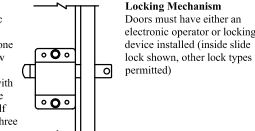

C Channels
4" x 2 1/2" 16 gauge 50 ksi c channels attached with one 1 1/4" wide 16 gauge strap, one 1/4" x 5/8" self tapping screw and three 1/4" x 1 1/4" lag screws per stile and boxed with one 3/76" x 2 3/8" 12 gauge plate and four 1/4" x 5/8" self tapping screw at the center three stile locations

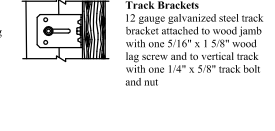

Locking Mechanism
Doors must have either an electronic operator or locking device installed (inside slide lock shown, other lock types permitted)



Track Brackets
12 gauge galvanized steel track brackets attached to wood jamb with one 5/16" x 1 5/8" wood lag screw and to vertical track with one 1/4" x 5/8" track bolt and nut

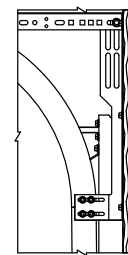

Flag Bracket
12 gauge galvanized steel flag bracket attached to wood jamb with three 5/16" x 1 5/8" wood lag screws and to the horizontal and vertical tracks with two 1/4" x 5/8" track bolts and nuts each

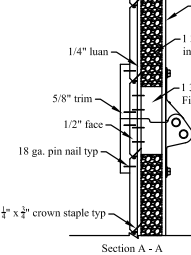

Horizontal Track and Angle
Horizontal track and angle to suit

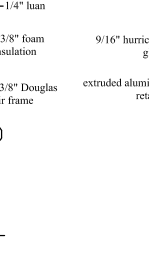

Vertical Track
2" galvanized steel track with a minimum thickness of .083" or 3" galvanized steel track with a minimum thickness of .090"

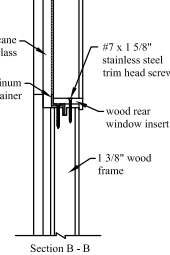

Section A - A

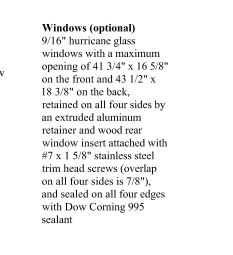

Section B - B

Windows (optional)
9/16" hurricane glass windows with a maximum opening of 41 3/4" x 16 5/8" on the front and 43 1/2" x 18 3/8" on the back, retained on all four sides by an extruded aluminum retainer and wood rear window insert attached with #7 x 1 5/8" stainless steel trim head screws (overlap on all four sides is 7/8"), and sealed on all four edges with Dow Corning 995 sealant

Note: The design of the supporting structural elements shall be the responsibility of the professional of record for the structure and in accordance with current building codes for the loads listed on this document

Models: Design 101-108, 201-203
Tested in accordance with ANSI/DASMA 108 and ANSI/DASMA 115
Design Pressure: +36.1/-40.2 PSF
Test Pressure: +54.15/-60.3 PSF
DRAWN BY:
John M. Stroede 6/5/18
APPROVED BY:
John M. Stroede 6/5/18

15711 MAIN ST HWY 19
OLD FORT, NC 28762

PHONE 828-668-1600
FAX 828-668-1805

TITLE
18x8 Carriage House Door +36.1/-40.2 PSF

| | |
|--|----------------------|
| DRAWING NUMBER Carriage-18-8-36-40 | REVISION A |
| SIZE B | SCALE N/A |
| SHEET 1 of 1 | |